

STRALIS 6x4 AD/AT



THE COMFORTABLE CHOICE

IVECO

STRALIS 6x4 AD/AT



SAFETY

- BUMPER INTEGRATED STEPS FOR EASY WINDSCREEN CLEANING
- 3 POINTS OF CONTACT FOR EASY ENTRY AND EGRESS
 - DISC BRAKES WITH ABS
 - ANTI SLIP REGULATOR (ASR)
- FRONT UNDERRUN PROTECTION



COMFORT

- 2280MM WIDE CAB WITH A CHOICE OF DAY OR INTEGRATED SLEEPER CAB
- PNEUMATICALLY CONTROLLED ADJUSTABLE STEERING COLUMN
- DRIVER AND PASSENGER AIR SUSPENDED FULLY ADJUSTABLE, HEATED SEATS
- BUNK ACCESSIBLE CONTROL MODULE



PRODUCTIVITY

- IMPRESSIVE FUEL EFFICIENCY
- AUTOMATED TRANSMISSION FOR OPTIMAL GEAR SELECTION
- AERODYNAMIC CAB STYLING
- IDEAL FOR SINGLE TRAILER, RIGID, TIPPER AND 19M B-DOUBLE APPLICATIONS

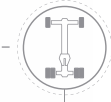

HANDLING

- SUPERIOR TURNING CIRCLE
- CAB AIR SUSPENSION FOR DRIVER COMFORT
- ZF EUROTRONIC II AUTOMATED TRANSMISSION WITH CRUISE CONTROL



PERFORMANCE

12.9 LITRE IVECO CURSOR 13 (EURO 5) ENGINE

UP TO 500HP AND 2300NM OF TORQUE

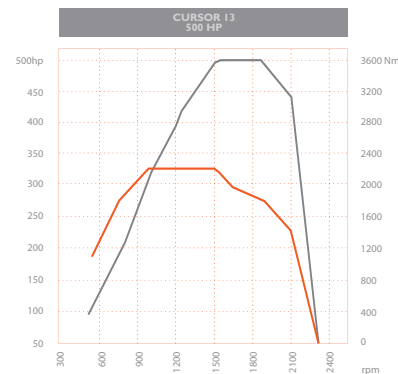
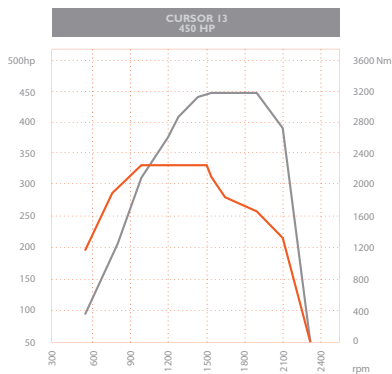

ENGINE 450hp IVECO Cursor 13 (EURO 5)
Optional: 500hp IVECO Cursor 13 (EURO 5)

Maximum Output:	450hp/336kW 500hp/373kW	Total Displacement:	12.9 litre
Maximum Torque:	1622 lb ft/2200 Nm @ 1000 rpm 1696 lb ft/2300 Nm @ 1000 rpm	Exhaust:	Horizontal catalytic muffler with integrated SCR catalyser
Emissions Technology:	Selective Catalytic Reduction		



P E R F O R M A N C E

EUROTRONIC AUTOMATED TRANSMISSION

13 LITRE 450/500 HP SCR ENGINE
EXTENDED OIL AND SERVICE INTERVALS
IVECO TURBO BRAKE WITH VGT
8 BAG REAR SUSPENSION WITH ECAS



W A R R A N T Y

24 MONTHS* / 500,000 KM / 6,000 HOURS / 100% PARTS AND LABOUR

This warranty commences on the earlier of the date of delivery of the truck to the Purchaser or the date of registration of the Vehicle.
This warranty ends on the earliest of the expiry of the duration, kilometres or hours.

Stralis Vehicles used off highway for 10% or more of total usage by kilometres will be covered by a 12 month duration warranty only.
Terms and Conditions apply, please see www.iveco.com.au for further details.

STRALIS 6x4 AD/AT

CHASSIS DIMENSIONS (mm)

	Prime mover	Rigid
WB	3900	6200
GC (Front)	244	244
GC (Rear)	290	290
AF	1475	3400
L	6785	11010
Turning circle*	14390	22890

*For wall to wall, add 1270mm

CAB DIMENSIONS (mm)

	H (Unladen)
Low roof	3085
Low roof with aerokit	4000
Medium roof	3585
Medium roof with aerokit	4000

SUSPENSION (mm)

	IVECO 8 Bag
B	697.5
C	697.5
D (Laden)	1040
D (Unladen)	1032

MASS RATINGS

- GVM 25.IT
- GCM 65.0T (450hp)
- GCM 75.0T (500hp)
- Chassis mass front 4.8 tonnes*
- Chassis mass rear 3.3 tonnes*
- Chassis mass total 8.1 tonnes*

*3.9m WB Active Day Cab Chassis with oil and coolant, but no fuel, spare wheel or tyre.

FRONT AXLE & SUSPENSION

- IVECO 5876

Type: Forged steel I-beam

Capacity: 7.5 tonnes

Suspension Type: Parabolic leaf springs and double acting shock absorbers

Capacity: 7.5 tonnes

REAR AXLE & SUSPENSION

- Meritor MT23-155 single reduction

Ratios: 3.40, 3.78

- Driver controlled differential locks

Suspension Type: IVECO 8 Bag with ECAS to control ride height and double acting telescopic shock absorbers.

Capacity: 21.0 tonnes

BRAKES

Type: 4-circuit air system

Front: 432mm Knorr disc brakes

Rear: 432mm Knorr disc brakes

- Wabco E 4-channel ABS/EBL and ASR

- Semi trailer air connections

- 130 litre aluminium air reservoirs

STEERING

- ZF 8098 power-assisted with gear-driven pump
- 460mm diameter adjustable steering wheel

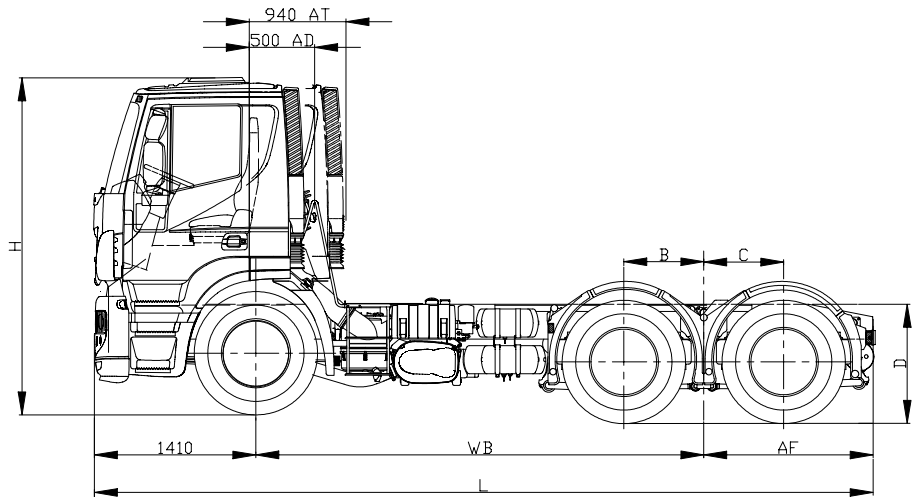

FUEL SYSTEM

- 1 x 500 litre rectangular aluminium tank (RHS)
- 1 x 100 litre AdBlue tank
- Optional:** 1 x 640 litre (RHS) + 1 x 310 litre (LHS) rectangular aluminium tanks = 950 litres
- 1 x split 250/250 (fuel/oil) litre tank (RHS) + 1 x 310 litre (LHS)

TRANSMISSION

- IVECO Eurotronic II I6AS2630 TO automated 16 speed overdrive
- Two-pedal operation with automatic or manual shift control

CHASSIS

Type: 304 x 80 x 7.7mm parallel-section medium tensile steel channel

- Polypropylene bumper with fog and driving lights
- FUPS
- Tapered rear of frame with fifth wheel angles (Prime Mover)
- Square end of frame with trailer connections to ROF (Rigid)

Optional: Polished aluminium bullbar with fog and driving lights

- Polished aluminium bumper with fog and driving lights

ELECTRICAL SYSTEM

Type: 24 volt

- Multiplex computerised CANBUS integrated wiring and systems control network with centralised colour display, controls and diagnostics

Batteries: 4 x 560 amps with automatic isolation switch

Alternator: 24V, 90 amps

WHEELS & TYRES

Wheels: 8.25DC x 22.5 10-stud 335mm PCD steel disc

Front tyres: Dunlop SP350* 295/80R22.5

Rear: Dunlop SP431A* 11R22.5

Optional: Alcoa 8.25DC x 22.5 10 stud 335mm PCD alloy

- Plain or Durabright finish
- Alternative tyre sizes, brands and tread patterns available

*Or different brand, equivalent model

COOLING SYSTEM

- Radiator frontal area: 1051in²
- Charge air cooler frontal area: 775in²

DRIVELINE

- Spicer 2000 series compact maintenance free shafts

CAB CONSTRUCTION

- IVECO Active Day 2280mm wide, all steel, forward control low roof day cab
- IVECO Active Time 2280mm wide, all steel, forward control low roof sleeper cab
- Four-point cab mounting system with air suspension and dampers at rear
- Hydraulic cab tilt

Optional: IVECO Active Time, medium roof sleeper cab with cooler box and roof hatch

CAB FEATURES

- Fully adjustable ISRI self levelling air suspension driver's seat with headrest, armrest, adjustable damper and integrated lap-sash retractor seat belt
- Fixed ISRI passenger seat with lap-sash retractor seat belt
- Active Time sleeper cab with 2020 x 620mm lower bunk mattress and privacy curtains
- 90° opening doors with electronically operated windows
- Radio/CD MP3 player with Bluetooth and steering wheel controls
- Storage lockers and compartments above console and below bunk
- Air conditioning with climate control
- Optional:** Roof deflector & side extenders
- Side extenders only

IVECO