

ENGINE

IVECO Cursor 10 E4
SCR (Selective Catalytic Reduction)
Type: Turbo charged, after-cooled, electronically direct injected four stroke diesel with IVECO Turbo Brake (ITB).
Number of cylinders 6.
RAC HP rating: 58.1
Total displacement: 10.3 litres.
Maximum output: 450hp/336kw @ 1900rpm.
Maximum torque: 1550lb ft/2102Nm @ 1000rpm.
Horizontal catalytic muffler with SCR catalyser integrated into exhaust.

TRANSMISSION

IVECO EuroTronic II 12AS2330 TD
Input torque 2300Nm.
Automated 12-speed direct drive. Two-pedal operation with automatic or manual shift control.
(Rev: 14.68/11.41:1, 1st:15.86:1, 12th: 1.00:1)
With oil cooler.

REAR AXLE

Meritor MT23-155
Single Reduction tandem axles with maintenance free unit bearings.
Capacity: 21.0 tonnes.
Ratios: 3.09
Driver controlled differential locks.

REAR SUSPENSION

IVECO 8 Bag (4 air bags per axle)
ECAS (Electronically Controlled Air Suspension) to control ride height.
Dual anti-sway bars and Double acting Telescopic Shock Absorbers.
Capacity: 22.0 tonnes.

CLUTCH

Self-adjusting single-plate with air assisted hydraulic actuation.
Diameter: 430mm.

FRONT AXLE

IVECO 5876
Type: Forged steel I-beam.
Capacity: 7.5 tonnes.

FRONT SUSPENSION

Two 1900mm x 90mm parabolic leaf springs with rubber bump stops, 45mm diameter anti-roll bar and Double acting Telescopic Shock Absorbers.
Capacity: 7.5 tonnes

BRAKES

Type: 4-circuit air system.
Front: Knorr ventilated disc brake.
Diameter: 432mm.
Pad area: 784cm²
Rear: Knorr ventilated disc brake.
Diameter: 432mm.
Pad area: 1568cm²
130-litre aluminium air reservoirs.
Desiccant type air dryer/pressure regulator.
Semi-trailer air connection.
Wabco E 4-channel ABS/EBL and ASR.

STEERING

ZF 8098 power-assisted with gear-driven pump.
460mm diameter adjustable steering wheel.

FUEL SYSTEM

Rectangular aluminium alloy tank.
1 x 600 litres (RHS).
1 x 55 litres of AdBlue (RHS).
Fuel Pro primary filter.

WHEELS AND TYRES

Wheels: 8.25DC x 22.5 10-stud 335mm steel disc.
Front tyres: Michelin XZE2, 295/8022.5 (or equivalent).
Rear tyres: XDE2, 295/80R22.5 (or equivalent).

CHASSIS

Type: 304mm x 80mm x 7.7mm parallel-section medium-tensile steel channel.
Yield strength: 490 MPa.
Section modulus: 258cm³
Polypropylene bumper with Fog & Driving lights.
Tapered end of frame.
Fifth wheel mounting angles.
Deck plate.
FUPD for 6.5t front axle loading.

ELECTRICAL SYSTEM

Type: 24-Volt, negative to earth.
Multiplex computerised CANBUS integrated wiring and systems control network with centralised colour display, controls and diagnostics.
Batteries: 2 x 220 amps SAE cold cranking current per battery, with automatic isolation switch.
Alternator: 24V, 90 amps.
Headlamps: 70/75 watt.
Rear flood light.
Semi-trailer HD ISO 7-pin socket.
12 Volt power outlet in dash.
Trailer connections.
70 Watt fog and driving lamps.
24-12 Volt converter for trailer lighting.
Tail light brackets.

COOLING SYSTEM

Radiator frontal area: 6780cm²
Charge air cooler frontal area: 5000cm²
Two-speed electronic magnetic fan, controlled by VCM and Mux system.

DRIVELINE

Spicer 2000 Series compact maintenance free shafts.

CAB

CONSTRUCTION

IVECO Active Time 2280mm wide, all steel, forward control sleeper cab with low roof. 2350mm BBC.
Four-point cab mounting system with air suspension and dampers on the front and rear. Hydraulic cab tilt to 60°.

S T R A L I S

ATi 6x4
AT440S45T/P-TZ
SPECIFICATIONS

IVECO

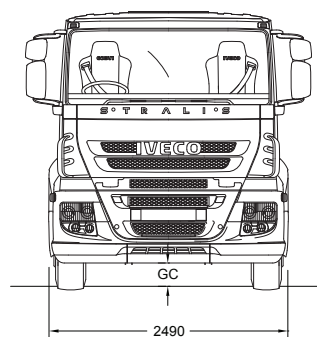
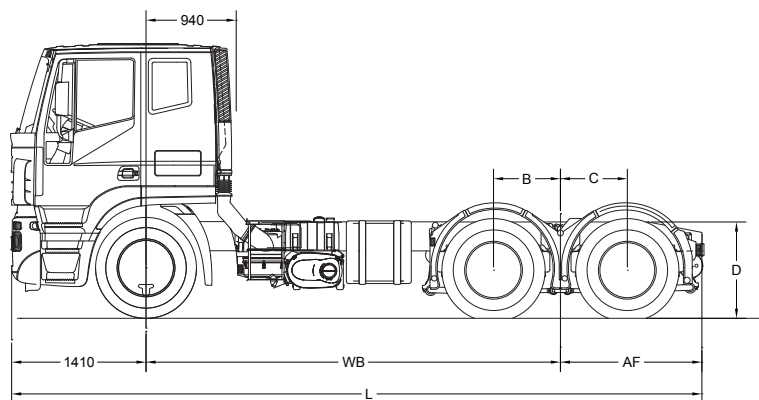

FEATURES

Active Time sleeper bunk with 2090mm x 670mm x 120mm mattress. Privacy curtains for windows and bunk area. Lockers below lower bunk with access from cab and external access doors. Fully adjustable ISRI self leveling air suspension driver's seat with headrest, adjustable damper and integral lap-sash retractor seat belt. Armrest with command buttons for power windows & adjustments. Fixed ISRI passenger seat with lap sash retractor seat belt. 90° opening doors with electrically operated window. Stowage locker in overhead console and compartments on left hand door and rear wall of cab. Remote central locking and immobilizer.

ACCESSORIES

Two internal sun visors with shade cloth blinds on side windows. Dark grey acrylic exterior sun visor. Aerodynamic powered and heated mirrors, a spotter mirror on each side and a curb view mirror on the passenger side. Manually controlled air conditioning. Heater demister with 4-speed fan. Demist ducts to door glasses. 2-speed and intermittent action twin windscreen wipers/washers. AM/FM radio/CD player with steering wheel controls. Dual roof-mounted air horns. Soft feel dashboard with multi-functional steering wheel, incorporating touch button menu controls. IVECO Colour Display (ICD) instrument panel. Satin silver finish instrument dial surrounds. Cluster with white scales and dark background. Electronic speedometer and tachometer, fuel level gauge, engine coolant temperature gauge, and ICD displays for air pressure, system voltage, engine oil level, pressure and temperature, engine coolant temperature. Warning lights in ICD for power divider, differential locks, park brake, engine brake, high beam, fog and driving lights, parking lights, turn signal, hazard lights, low air pressure, brake system fault, park brake, mirror heaters. The ICD also gives information on Hi-Fi settings and control, Clock and alarm settings, trip data and trip computer, diagnostics, mirror adjustments and Eurotronic transmission, functions. Cruise control. AdBlue level. Air controls mounted in centre dash console for park brake, inter-axle locks and cross-diff locks.

Gear control lever on steering column. Fully adjustable steering column with floor release switch. Air controls mounted in centre dash console for park brake, inter-axle locks and cross-diff locks.

FINISH

White painted cab and bumper with white steps and fenders. Cab treated with anti-corrosion protection and metallic joints treated with vinyl sealant. Anti scratch treatment on cab underbody.

MASS RATINGS

GVM 25.1 tonnes.
GCM 50.0 tonnes.

Chassis mass front 4.61 tonnes.
Chassis mass rear 3.40 tonnes.
Chassis mass total 8.01 tonnes.
Chassis with day cab, oil and coolant, but no fuel, spare wheel or tyre.

SUSPENSION (Dimensions in mm)

	B	C	D Laden	D Unladen
IVECO 8 Bag	697.5	697.5	1040	1032

CHASSIS DIMENSIONS (Dimensions in mm)

WB	3900
GC (Front)	230
GC (Rear)	245
AF	1475
L	6815
Turning circle*	15980

*For wall to wall, add 1270mm

CAB (Dimensions in mm)

	H
Active Time	2941

Iveco Trucks Australia Limited

A.B.N. 86 004 065 061
Princes Hwy, Dandenong, Victoria 3175
P.O. Box 117 Dandenong, Victoria 3175
Telephone: (03) 9238 2200
Facsimile: (03) 9238 2387
www.iveco.com.au

Stralis Spec Sheet (MARCH 2009)

STRALIS

ATi 6x4
AT440S45T/P-TZ
SPECIFICATIONS

IVECO