

AS-L 6x4 Specification Sheet

ENGINE

Iveco Cursor E4
 SCR (Selective Catalytic Reduction)
 Type: Turbo charged, after-cooled, electronically direct injected four stroke diesel with Iveco Turbo Brake (ITB).
 Number of cylinders 6.
 RAC HP rating: 67.8
 Total displacement: 12.9 litres.
 Maximum output: 500hp/373kw @1575-1900rpm.
 Maximum torque: 1696lb ft/2300Nm @1000-1575rpm.
 280mm dry-element Donaldson air cleaner.
 Horizontal catalytic muffler with SCR catalyzer integrated into exhaust.
Optional:
 Iveco Cursor 13, 560hp/418kw.
 with 1840lb ft/2495Nm of torque.

TRANSMISSION

Iveco EuroTronic II 16AS2630 TO
 Input torque 2600Nm.
 Automated 16-speed overdrive. Two-pedal operation with automatic or manual shift control.
 (Rev: 13.07/10.81:1, 1st:14.12:1, 16th: 0.83:1)
 With oil cooler.

REAR AXLE

Meritor MT23-155
 Single Reduction tandem axles with maintenance free unit bearings.
 Capacity: 21.0 tonnes.
 Ratios: 3.42, 3.78, 4.13
 Driver controlled differential locks.

REAR SUSPENSION

Iveco 8 Bag (4 air bags per axle)
 ECAS (Electronically Controlled Air Suspension) to control ride height.
 Dual anti-sway bars and Double acting Telescopic Shock Absorbers.
 Capacity: 22.0 tonnes.

CLUTCH

Self-adjusting single-plate with air assisted hydraulic actuation.
 Diameter: 430mm.

FRONT AXLE

Iveco 5876
 Type: Forged steel I-beam.
 Capacity: 7.5 tonnes.

FRONT SUSPENSION

Two 1900mm x 90mm parabolic leaf springs with rubber bump stops, 45mm diameter anti-roll bar and double acting telescopic shock absorbers.
 Capacity: 7.5 tonnes

BRAKES

Type: 4-circuit air system.
 Front: Knorr ventilated disc brake.
 Diameter: 432mm.
 Pad area: 784cm².
 Rear: Knorr ventilated disc brake.
 Diameter: 432mm.
 Pad area: 1568cm².
 130-litre aluminium air reservoirs.
 Desiccant type air dryer/pressure regulator.
 Semi-trailer air connections.
 Wabco E 4-channel ABS/EBL and ASR.
Optional:
 Trailer ABS facility.

STEERING

ZF 8098 power-assisted with gear-driven pump.
 460mm diameter adjustable steering wheel.

FUEL SYSTEM

Rectangular aluminium alloy tanks.
 Total of 1300 litres in three tanks.
 1 x 100l of AdBlue.
 Fuel Pro primary filter.

CHASSIS

Type: 289x80x7.7mm parallel-section medium tensile steel channel.
 Section modulus: 258cm³.
 PP (Polypropylene) Bumper with Fog & Driving lights.
 Front Under-Run Protection device.
 Tapered end of frame.
 Fifth wheel mounting angles.
 Deckplate.
Optional:
 Polished-alloy bull bar w/ Fog & Driving lights.
 Polished-alloy bumper w / Fog & Driving lights.

ELECTRICAL SYSTEM

Type: 24-Volt, negative to earth.
 Multiplex computerised CANBUS integrated wiring and systems control network with centralised colour display, controls and diagnostics.
 Batteries: 4 x 560 amps SAE cold cranking current per battery, with automatic isolation switch.
 Alternator: 24V, 90 amps.
 Headlamps: 70/75 watt.
 Rear flood light.
 Semi-trailer HD ISO 7-pin socket.
 12 Volt power outlet in dash.
 Trailer connections.
 70 Watt fog and driving lamps.
 24-12 Volt converter for trailer lighting.
 Tail light brackets.

WHEELS AND TYRES

Wheels: 8.25DC x 22.5 10-stud 335mm PCD Alcoa Alloy wheels with Dura-bright finish.
 Front tyres: Michelin XZE2+, 295/80R22.5
 Rear: Michelin XDE2, 11R22.5
 Spare: Wheel without tyre.

COOLING SYSTEM

Radiator frontal area: 8400cm².
 Charge air cooler frontal area: 5700cm².
 Three-speed electronic magnetic fan, controlled by VCM and Mux system.

DRIVELINE

Spicer 2000 Series Compact Maintenance Free Shafts.

CAB

Construction

Iveco Active Space 2489mm wide, all steel, forward control sleeper cab with flat floor.
 Four-point cab mounting system with air springs and dampers on the front and rear.
 Electro-hydraulic cab tilt to 60°.
 Remote central locking and immobilizer.

Features

Active Space sleeper bunk with 2020mm x 746mm lower sleeper bunk with 85mm thick mattress.
 Privacy curtains for windows and bunk area. Electrically operated clear sun roof hatch with blind.
 Lockers below lower bunk with access from cab and external access door. Additional lockers behind doors.
 Sliding storage box below bunk.
 Refrigerator integrated below bunk.
 Heavy duty washable floor mat with removable carpet.
 Fully 3-way adjustable ISRI self levelling air suspended driver's seat with pneumatic adjustable lumbar support, headrest and integral lap-sash retractor seat belt.
 For/aft movement ± 40 mm.
 Air suspended ISRI passenger seat with lap sash retractor seat belt.
 90° opening doors with electrically operated windows.

Accessories

Full width electrically controlled internal sun visor with shade cloth blinds on side window.
 Dark grey acrylic exterior sunvisor.
 Aerodynamic powered and heated mirrors and convex spotter mirror on each side and a kerb view mirror on the passenger side.
 Climate control Air conditioning.
 Heater demister with 4-speed fan. Demist ducts to door glasses.
 2-speed and intermittent action twin windscreen wipers/washers.
 AM/FM radio/CD player with steering wheel controls and remote controls.
 Alarm clock and additional spotlight lights remotely operated.
 Dual roof-mounted air horns.
 Iveco Colour Display (ICD) instrument panel.
 Soft feel dashboard with multi-functional steering wheel incorporating touch button menu controls. Satin silver finish instrument dial surrounds. Cluster with white scales and dark background.
 Electronic speedometer and tachometer, fuel level gauge, engine coolant temperature gauge, and ICD displays for air pressure, system voltage, engine oil level, pressure and temperature, engine coolant temperature.
 Warning lights in ICD for power divider, DCDL, park brake, engine brake, high beam, fog and driving lights, parking lights, turn signal, hazard lights, low air pressure, brake system fault, mirror heaters. The ICD also gives information on Hi-Fi settings and control, Clock and alarm settings, trip data and trip computer, diagnostics, mirror adjustments and Eurotronic transmission functions. Cruise control.
 AdBlue level.
 Fully adjustable steering column with floor release switch.
 Air controls mounted in centre dash console for park brake, inter-axle locks and cross-diff locks.
 Gear control lever on steering column.
Optional:
 Leather Seats with arm rests & Steering wheel cover:

CAB - OPTION

High Roof Active Space

Premium option with high roof cabin, upper bunk and mattress with large supporting slats.
 2080mm floor to roof over driver's seat, 1060mm bunk to roof.
 Three compartment storage spaces above overhead console.
 Driver & passenger leather seats. Passenger seat with 4 degrees of freedom (swivel type - foldable). Leather steering wheel cover.

Aerodynamics

Roof Deflector & Side Extenders.

Finish

White painted cab and bumper with grey steps.
 Cab treated with anti-corrosion protection and metallic joints treated with vinyl sealant.
 Anti scratch treatment on the cab underbody.

MASS RATINGS

GVM 25.1 tonnes
 GCM up to 90.0 tonne
 Chassis mass front 4.84 tonnes
 Chassis mass rear 3.57 tonnes
 Chassis mass total 8.41 tonnes

Chassis with low roof cab, oil and coolant, but no fuel, spare wheel or tyre.

SUSPENSION (dimensions in mm)

	B	C	D	D
			Laden	Unladen
Iveco 8 Bag	697.5	697.5	1040	1032

CHASSIS DIMENSIONS (dimensions in mm)

WB	4050
GC(Front)	244
GC(Rear)	290
AF	1475
CA	2675
CF	4150
L	6935
H	3040
Turning circle**	15220

**For wall to wall, add 1300mm

Cab Style (dimensions in mm)

	H	CL
High roof sleeper W/Aero kit	3822	1375

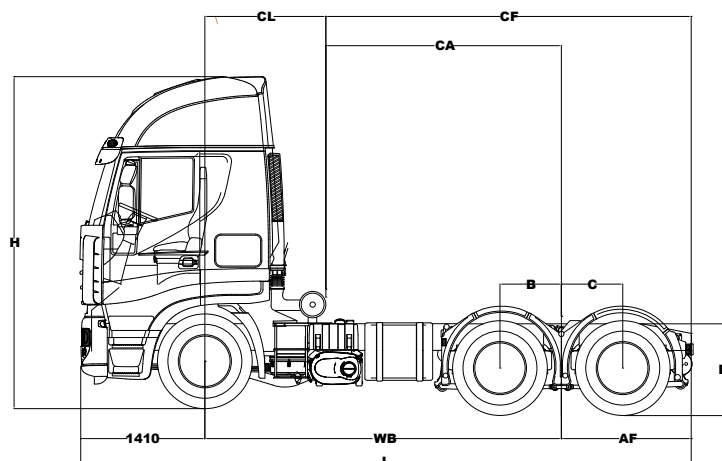

IVECO