

Chassis for School / Interurban / Tourist Coach

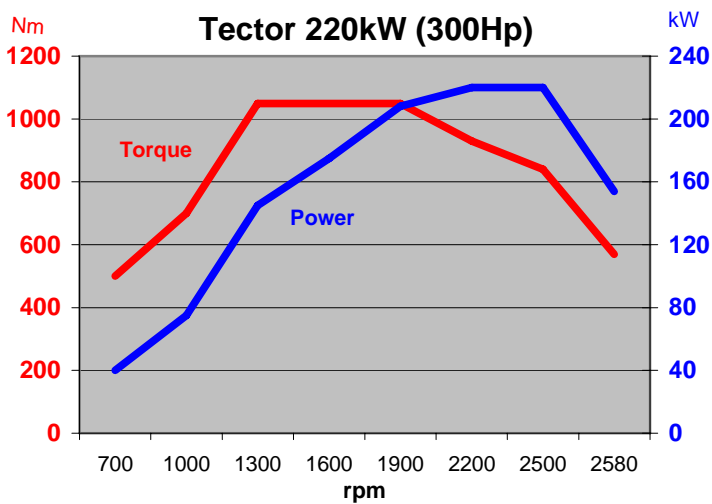

## GENERAL FEATURES

Chassis Length	8,204 mm
Chassis Width	2,309 mm
Chassis Wheelbase	3,700 mm
Front / Rear chassis overhang	1,744 / 2,760 mm
Overhang angles	> 7°
Bodied Wheelbase	4,600 – 5,900 mm
Bodied Length	9,500 -10,500 mm
Bodied Width	2,450- 2,550 mm
Bodied floor Height	550 – 1,100 mm
Max Slope	> 18°
Max Technical GVW	14,200 Kg
On front axle	5,000 Kg
On rear axle	9,200 Kg

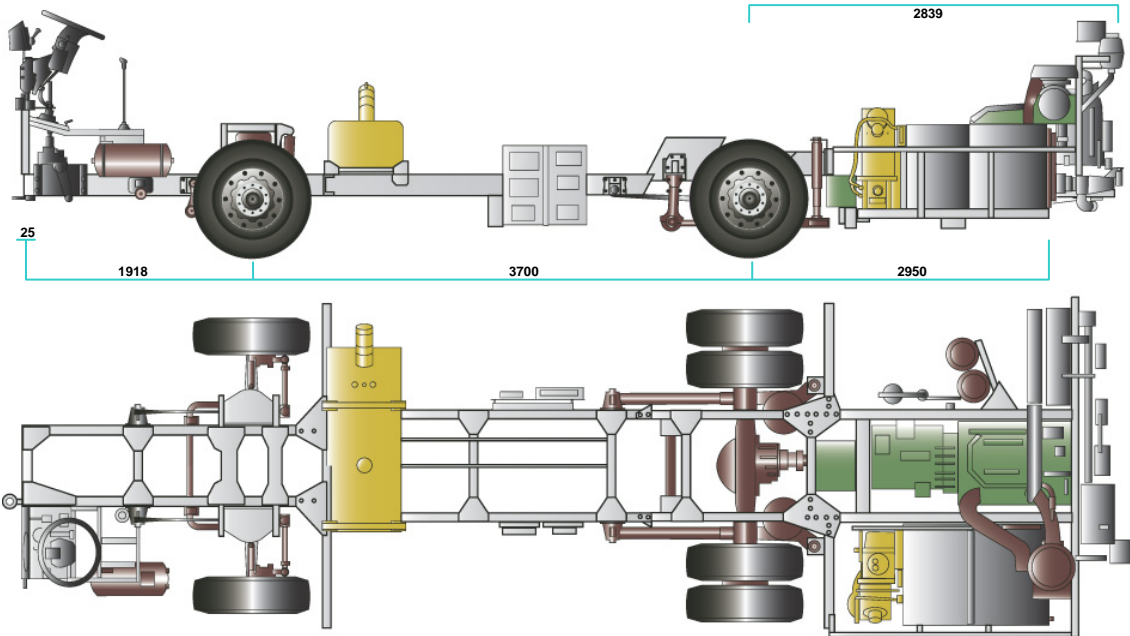

220 KW (300 Hp)  
**EURO 4**  
**Optional: EEV**

# MidiRider Tector

## ENGINE

Type IVECO TECTOR 6 mounted longitudinally at rear  
VGT Turbocharged (air-air) with intercooler, water cooled,  
4 stroke Diesel cycle

Electronically-controlled injection pump  
6 cylinders in line, 4 valves by cylinder

Decompression engine brake

Bore X Stroke 102 x 120 mm

Total Displacement 5 880 cm<sup>3</sup>

Max. power output 220 kW (300 Hp)

Max. torque 1050 Nm

Gassy emissions comply with Euro 4 Standards  
(88/77\*2005/55\*2005/78/CE)

Radiator and fan located on the rear overhang on the right-hand side; fan is belt actuated

Cruise control; integrated with speed limiter

Gear driven power steering compressor and pump with recirculating ball power steering

Double cartridge fuel filter. Fuel pre-filter with manual pump and water separator

Large capacity air filter with blockage warning

Manual start and cut-out in engine compartment

## CLUTCH

Single dry plate – 15.5" (395 mm) diameter

Hydraulically operated with full-type pneumatic assistance

Automatic clearance adjustment

## TRANSMISSION

ZF 6S-1200

1 <sup>st</sup>	7.72:1	4 <sup>th</sup>	1.92:1
2 <sup>nd</sup>	4.42:1	5 <sup>th</sup>	1.30:1
3 <sup>rd</sup>	2.86:1	6 <sup>th</sup>	1.00:1
		Reverse	7.10:1

Joy-Stick control of the gearbox.

ZF 6HP504C

1 <sup>st</sup>	3.43:1	4 <sup>th</sup>	1.00:1
2 <sup>nd</sup>	2.01:1	5 <sup>th</sup>	0.83:1
3 <sup>rd</sup>	1.42:1	6 <sup>th</sup>	0.59:1
		Reverse	4.84:1

## FRONT AXLE

Iveco Rigid Front Axle 5842 designed for air suspension

## REAR AXLE

Single reduction stress-bearing axle MC10 144

	ZF 6S-1200	ZF6HP504C	
Std ratio	3.73	4.88	

Other ratio available as opt.

## CHASSIS

In stress bearing steel

Constant width side members shaped above the front and rear axles, with reinforcements above and below welded to an adjustable central structure

Suitable for modular bodies, with the possibility of setting the wheelbase from 4 600 mm to 5 900 mm

## SUSPENSION

Full air suspension. Continuous automatic set-up correction, regardless of load conditions

Standard suspension set-up for high bodied vehicles

✚ Electronic controlled air suspension)

✚ Suspension adjustment for lifting/lowering

## BRAKES

Service and Emergency Brakes:

Dual circuits, one per axle. Foot brake acts on all wheels

Front axle: disc, pneumatic

Rear axle: drum, pneumatic

Brake wear sensor on pads/linings – both axles

Emergency braking by division of 2 circuits

ABS+ASR

Parking Brake:

Spring actuators on rear wheels, pneumatically controlled

Acts as an emergency brake if needed

Mechanical release in the event of failure

Emergency brake:

Acts on that part of the service brake, front or rear, which is not affected by the failure

Air system:

630 cm<sup>3</sup> twin cylinder compressor

Operating pressure 8.5 bar

Air dryer with regulator; centrifugal decanter

3 x 25 litre tanks and 1 x 5 litre tank

Retarder:

ZF 6S-1200: Telma electromagnetic

✚ Engine brake (available only with Telma)

Automatic gearbox: hydraulic integrated in gearbox, foot-pedal controlled

## DRIVE / STEERING

Right hand side driver's position.

Recirculating ball power steering, type ZF 8098

Steering Wheel diameter 470 mm, adjustable for height and rake

## WHEELS / TYRES

Disc Wheels 6,75 x 22,5"

Tyres 255/70 R 22,5

## ELECTRICAL SYSTEM

Supply Voltage 24 V; Batteries 2 x 12 V -180 Ah

Starter motor 4 kW

2 Alternator 90 – 90 A (28 V)

Fuse protected circuits, electromagnetic battery cut-out, power socket in rear compartment, provision for preventing operation when the doors are open

Central switch for emergency control

Anti-corrosion, water/dust proof connecting elements

## MISCELLANEOUS:

Electronic tachograph for 2 drivers (EC)

Fuel tank 250 l

AdBlue Tank: 60 l

✚ Main optional

Chassis for School / Interurban / Tourist Coach

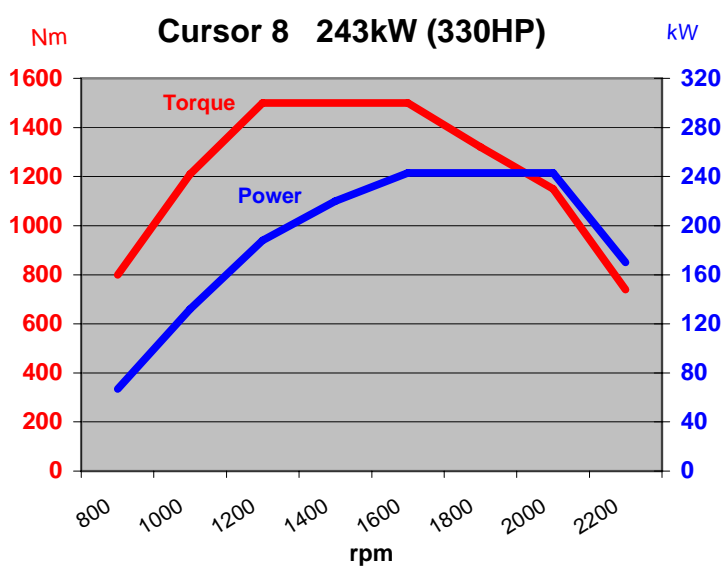
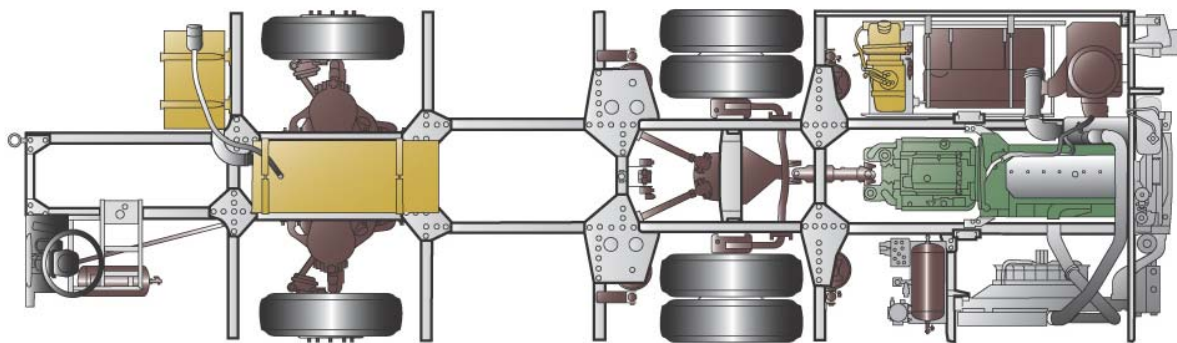
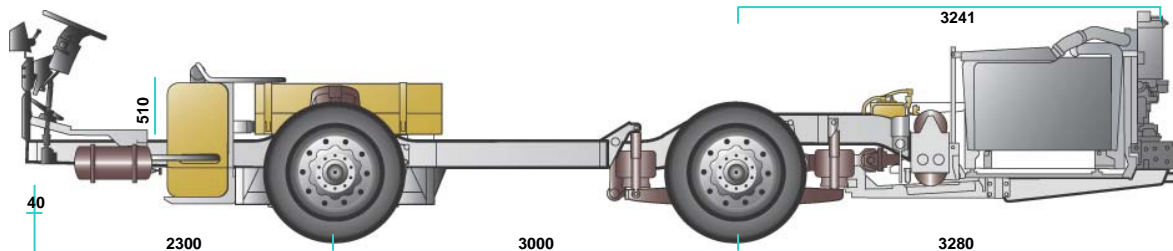

### GENERAL FEATURES

Chassis Length	8 620 mm
Chassis Width	2 486 mm
Chassis Wheelbase	3 000 mm
Front / Rear chassis overhang	2 340/ 3 280 mm
Overhang angles	> 7°
Bodied Wheelbase	5 900 - 6 900 mm
Bodied Length	11 400 -13 000 mm
Bodied Width	2 500 - 2 550 mm
Bodied Floor Height	800 – 1600 mm
Max Slope	> 18°
Max Technical GVW	19 000 Kg
On front axle	7 100 Kg
On rear axle	12 600 Kg



243 KW (330 Hp)



**EURO 4**

(Optional: EURO 5 or EEV)

# EuroRider Cursor 8

## ▶ ENGINE

Type IVECO CURSOR 8 mounted longitudinally at rear  
VGT Turbocharged (air-air) with intercooler, water cooled,  
4 stroke Diesel cycle  
Electronically-controlled injection pump.  
6 cylinders in line, 4 valves by cylinder  
Decompression engine brake  
Bore X Stroke 115 x 125 mm  
Total Displacement 7 790 cm<sup>3</sup>  
Max. power output 243 kW (330 Hp)  
Max. torque 1500 Nm 1080 – 1920 rpm  
Gassy emissions comply with Euro 4 Standards  
(88/77\*2005/55\*2005/78/CE)  
Radiator and fan located on the rear overhang on the left-hand side; longitudinal position hydrostatic operation  
Cruise control; integrated with speed limiter  
Gear driven power steering compressor and pump with recirculating ball power steering  
Double cartridge fuel filter. Fuel pre-filter with manual pump and water separator  
Large capacity air filter with blockage warning  
Manual start and cut-out in engine compartment

-  Euro 5
-  EEV

## ▶ TRANSMISSION

ZF 6S-1600			
1 <sup>st</sup>	7.72:1	4 <sup>th</sup>	1.79:1
2 <sup>nd</sup>	4.42:1	5 <sup>th</sup>	1.28:1
3 <sup>rd</sup>	2.66:1	6 <sup>th</sup>	1.00:1
		Reverse	7.1:1

Joy-Stick control of the transmission

ZF 6HP604C			
1 <sup>st</sup>	3.43:1	4 <sup>th</sup>	1.00:1
2 <sup>nd</sup>	2.01:1	5 <sup>th</sup>	0.83:1
3 <sup>rd</sup>	1.42:1	6 <sup>th</sup>	0.59:1
		Reverse	4.84:1

## ▶ FRONT AXLE

Independent Front Wheels ZF RL75E designed for air suspension



## ▶ REAR AXLE

Single reduction stress-bearing axle MC13 165

	ZF 6S-1600	ZF 6HP604C
Std ratio	3.21	4.56

## ▶ ELECTRICAL SYSTEM

Supply Voltage 24 V; Batteries 2 x 12 V -180 Ah  
Starter motor 4.5 kW  
2 Alternator 90 – 90 A (28 V)  
Fuse protected circuits, electromagnetic battery cut-out, power socket in rear compartment, provision for preventing operation when the doors are open  
Central switch for emergency control  
Anti-corrosion, water/dust proof connecting elements



-  2 Alternator 140 – 80 A (28 V)
-  2 Batteries 220 Ah

## ▶ CHASSIS

In stress bearing steel  
Constant width side members shaped above the front and rear axles, with reinforcements above and below welded to an adjustable central structure  
Suitable for modular bodies, with the possibility of setting the wheelbase from 5 900 mm to 6 900 mm

## ▶ SUSPENSION

Full air suspension. Continuous automatic set-up correction, regardless of load conditions  
Standard suspension set-up for high bodied vehicles.

-  Electronic controlled air suspension
-  Suspension adjustment for lifting/lowering

### Front axle:

2 air cushions, 2 dual-effects shock absorbers with 1 leveling valve; each wheel unit fixed by lower/upper triangular reaction bars and one anti-roll bar

### Rear axle:

4 air cushions, 4 dual-effect shock absorbers, one anti-roll bar and 2 leveling valves. Parallelogram-shaped section for fixing the axle to the chassis, with 2 lower longitudinally-positioned reaction bars and 2 upper reaction bars in a "V" configuration

## ▶ BRAKES

### Service and Emergency Brakes:

Dual circuits, one per axle. Foot brake acts on all wheels  
Front & Rear axle: disc, pneumatic; braking surface area 816x2 cm<sup>2</sup>

Brake wear sensor on pads/linings – both axles

Emergency braking by division of 2 circuits

ABS+ASR

### Parking Brake:

Spring actuators on rear wheels, pneumatically controlled

Acts as an emergency brake if needed

Mechanical release in the event of failure

### Emergency brake:

Acts on that part of the service brake, front or rear, which is not affected by the failure

### Air system:

630 cm<sup>3</sup> twin cylinder compressor

Operating pressure 8.5 bar

Air dryer with regulator; centrifugal decanter

3 x 25 litre tanks and 1 x 5 litre tank

### Retarder:

ZF 6S-1600: Telma electromagnetic or Intarder hydraulic

Automatic gearbox: hydraulic integrated in gearbox, foot-pedal controlled

## ▶ DRIVE / STEERING

Recirculating ball power steering, type ZF 8098

Steering Wheel diameter 470 mm, adjustable for height and rake

## ▶ MISCELLANEOUS

Electronic tachograph for 2 drivers (EC)

Fuel tank x 2 (260+240 l) total 500 l

AdBlue Tank: 60 l

## ▶ WHEELS / TYRES

Steel Disc Wheels 8,25 x 22,5"

Tyres Michelin 295/80 R 22,5

(Optional Alloy rims)

 Main optional

# IVECO

# EuroRider

## 6x2 CURSOR 10

### Chassis for Interurban / Tourist Coach

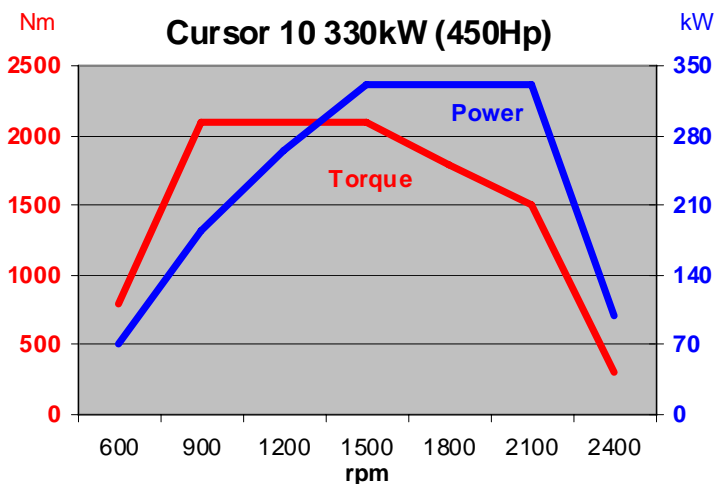
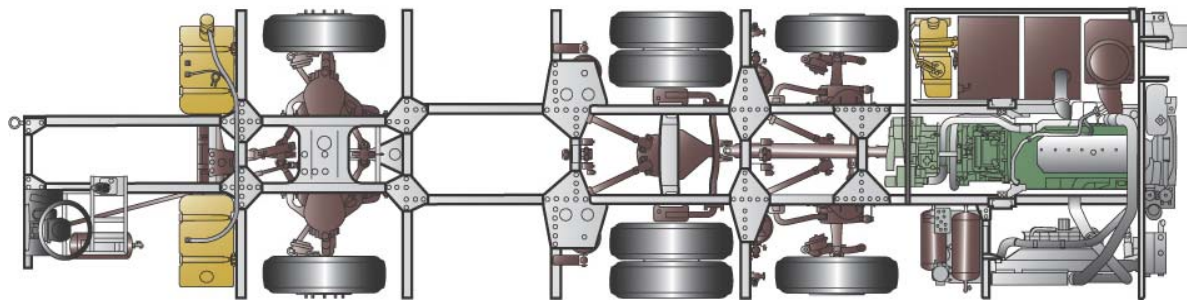
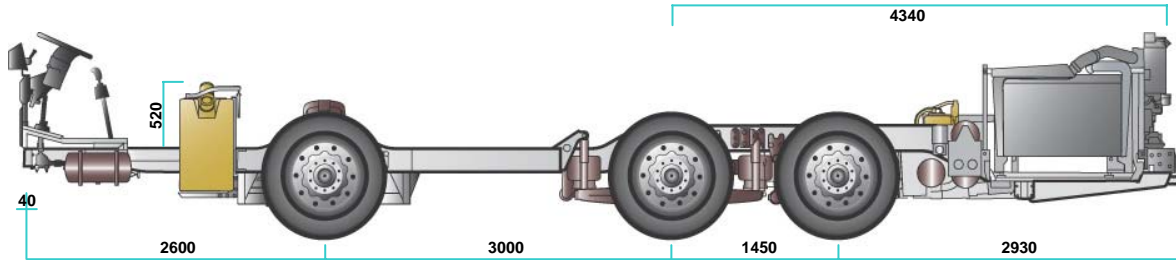

### GENERAL FEATURES

Chassis Length	10 020 mm
Chassis Width	2 498 mm
Chassis Wheelbase	3 000 / 1 450mm
Front / Rear chassis overhang	2 640/2930 mm
Overhang angles	> 7°
Bodied Length	13 200 – 15 000 mm
Bodied Width	2 500 – 2 550 mm
Bodied floor Height	800-1 600 mm
Max Slope	> 18°
Max Technical GVW	24 500 Kg
On front axle	7 100 Kg
On rear axle	12 000 / 5 500 Kg



330 KW (450 Hp)

**EURO 4**

# Eurorider 6x2 Cursor 10 Chassis

## ENGINE

Type IVECO CURSOR 10 mounted longitudinally at rear VGT Turbocharged (air-air) with intercooler, water cooled, 4 stroke Diesel cycle

Electronically-controlled injection pump

6 cylinders in line, 4 valves by cylinder

Decompression engine brake

Total Displacement 10 litres

Max. power output 330 KW (450 Hp)

Max. torque 2100 Nm

Measured in accordance to standard 88/195/EC

Gassy emissions comply with CE 88/77\*2001/27A

Euro 4 Standards

🚗 Euro 5

🚗 EEV

Radiator and fan located on the rear overhang on the left-hand side in a longitudinal position; hydrostatic operation

Cruise control; integrated with speed limiter

Gear driven power steering compressor and pump with recirculating ball power steering

Double cartridge fuel filter. Fuel pre-filter with manual pump and water separator

Large capacity air filter with blockage warning

Manual start and cut-out in engine compartment

## TRANSMISSION

ZF AsTronic 12 (for 450Hp version)

1 <sup>st</sup>	12.53	7 <sup>th</sup>	2.70
2 <sup>nd</sup>	9.59	8 <sup>th</sup>	2.10
3 <sup>rd</sup>	7.44	9 <sup>th</sup>	1.63
4 <sup>th</sup>	5.78	10 <sup>th</sup>	1.27
5 <sup>th</sup>	4.75	11 <sup>th</sup>	1.00
6 <sup>th</sup>	3.55	12 <sup>th</sup>	0.78
		Reverse	11.41

### Retarder:

ZF Astronic: integrated in gearbox, foot-pedal controlled

## FRONT AXLE

Independent Front Wheels ZF RL75E designed for air suspension

## REAR AXLE

Axle 1: Single reduction stress-bearing axle, MC13-175

Axle 2: Rigid IVECO 5876 with driven wheels

	ZF AsTronic
Std ratio	3.36

Other ratio available as opt.

## ELECTRICAL SYSTEM

Supply Voltage 24 V

Batteries 2 x 12 V -180 Ah

Starter motor 5.5 kW

2 Alternator 140 – 80 A (28 V)

Fuse protected circuits, electromagnetic battery cut-out, power socket in rear compartment, provision for preventing operation when the doors are open

Central switch for emergency control

Anti-corrosion, water/dust proof connecting elements.

🚗 2 Batteries 220 Ah

## CHASSIS

In stress bearing steel

Constant width side members shaped above the front and rear axles, with above and below welded to an adjustable central structure

Suitable for modular bodies, with the possibility of setting the wheelbase from 6150 mm to 7150 mm

## SUSPENSION

Full Pneumatic. Continuous automatic set-up correction, regardless of load conditions

Standard suspension set-up for high bodied vehicles

🚗 Electronic controlled air suspension

🚗 Suspension adjustment for lifting/lowering

### Front axle:

2 air cushions, 2 dual-effects shock absorbers with leveling valve; each wheel unit fixed by lower/upper triangular reaction bars and one anti-roll bar

### Rear axle 1:

4 air cushions, 4 dual-effect shock absorbers, one anti-roll bar and 2 leveling valves. Parallelogram-shaped section for fixing the axle to the chassis, with 2 lower longitudinally-positioned reaction bars and 2 upper reaction bars in a "V" configuration

Rear axle 2: 2 air cushions, 2 dual-effects shock absorbers with leveling valve

## BRAKES

### Service and Emergency Brakes:

Dual circuits, one per axle

Foot brake acts on all wheels

Front & Rear axle: disc, pneumatic; braking surface area 816x2 cm<sup>2</sup>

Brake wear sensor on pads/linings – both axles

Emergency braking by division of 2 circuits

ABS+ASR

### Parking Brake:

Spring actuators on rear wheels, pneumatically controlled

Acts as an emergency brake if needed

Mechanical release in the event of failure

### Emergency brake:

Acts on that part of the service brake, front or rear, which is not affected by the failure

### Air system:

630 cm<sup>3</sup> twin cylinder compressor

Operating pressure 8.5 bar

Air dryer with regulator; centrifugal decanter

3 x 25 litre tanks and 1 x 5 litre tank

20 litre tank with ZF Astronic gearbox

## DRIVE / STEERING

Recirculating ball power steering, type ZF 8098

Steering Wheel diameter 470 mm, adjustable for height and rake

## WHEELS / TYRES

Steel Disc Wheels 8,25 x 22,5"

Tyres Michelin 295/80 R 22,5

(Optional Alloy rims)

## MISCELLANEOUS:

Electronic tachograph for 2 drivers (EC)

2 Fuel tank x 250 l - total 500l in steel

AdBlue tank 60l

🚗 Main optional

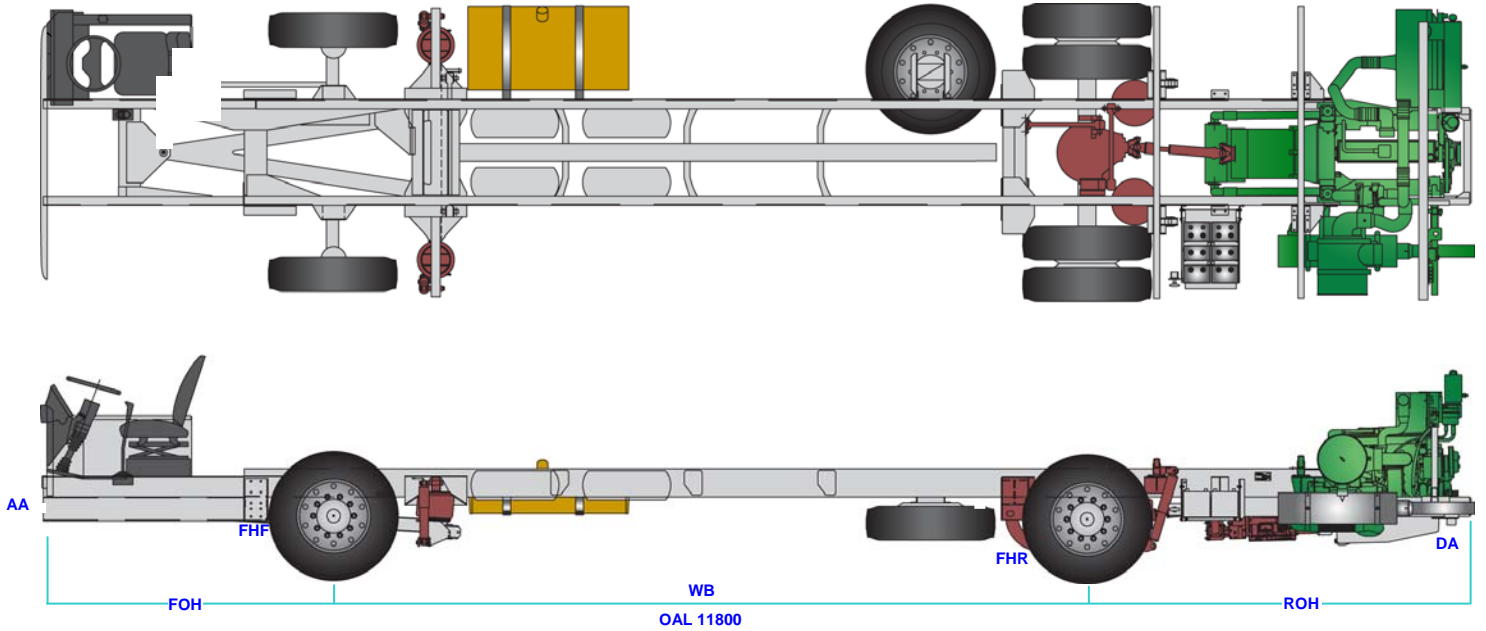

## GENERAL FEATURES

	Short Wheelbase	Long Wheelbase
Chassis Length	10058	11800
Chassis Width	2403	2403
Chassis Wheelbase	5100	6200
Front / Rear chassis overhang	F: 2041 R: 2912	F: 2400 R: 3200
Front track	2013	2013
Rear track	1803	1830
Overall width	2403	2430
Overhang angles	Approach : >11° Departure : >7°	
Bodied Wheelbase	Dependant upon body builder	
Bodied Length	10900mm	12500mm
Bodied Width	2500	2500
Bodied floor Height	Dependant upon body builder	
Frame height front	884	884
Frame height rear	919	919
Max Technical GVW	17630	17630
On front axle	6630	6630
On rear axle	11000	11000

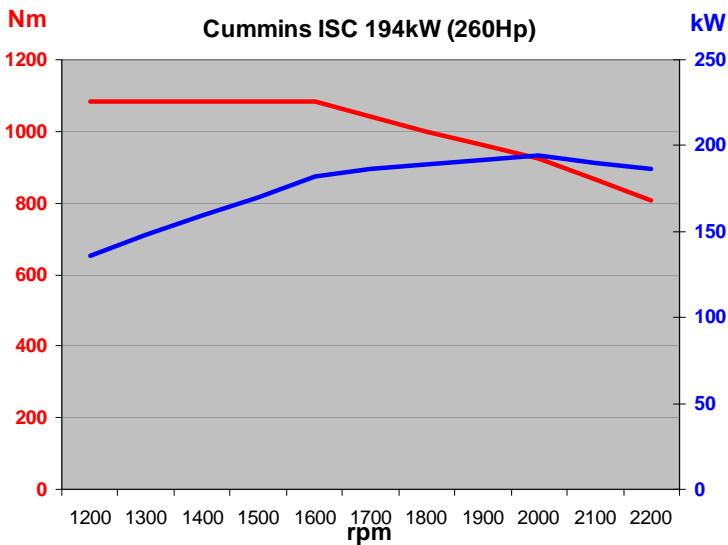

194 KW 260 Hp (Optional 300Hp)

**EURO 4**



**NON SCR NON EGR**

# Delta Euro 4 Chassis

## ENGINE

Cummins ISC 05 80/02 8.3L turbocharged engine with (air-air) intercooler, water cooled, 4 stroke diesel cycle, 6 cylinders in line, EDC control

### 260Hp ADR 80/02 Emission

Total displacement 8300 cm3  
 Max. Output 194 kW (260hp) at rpm 2200  
 Torque 1085Nm (800 lbs./ft)  
 1200 – 1600 rpm

### (Optional 300Hp)

Total displacement 8300 cm3  
 Max. Output 224 kW (300hp) at rpm 2000  
 Torque 1166Nm (860 lbs./ft)  
 1300 – 1600 rpm

## TRANSMISSION

Automatic Allison World Series T350R Fully auto 5 speed with torque converter and integrated hydraulic retarder  
**(6 speed optional)**

Ratios			
1 <sup>st</sup>	3.49:1	4th	1.00:1
2 <sup>nd</sup>	1.86:1	5th	0.75:1
3 <sup>rd</sup>	1.41:1	6th	0.65:1
		Reverse	5.03:1

## FRONT AXLE

Spicer I 140 rigid designed for air suspension

## REAR AXLE

Meritor MC11-165 fully floating single reduction 5.38:1

## SUSPENSION

### FRONT SUSPENSION

Wide stance low profile air suspension with heavy duty shock absorbers located outbound and dual height control valves.

### REAR SUSPENSION

Neway AD123 airbag suspension with heavy duty shock absorbers and single height control valve.

## BRAKES

### Service

Dual air system S-cam.  
 Front drum 419 x 152mm  
 Rear drum 419 x 178mm  
 Total lining area 5330cm  
 510 litre/min compressor auto slack adjuster  
 Parking brake: mechanical spring actuator with air control and emergency locking device on the rear wheels

### (ABS optional)

## RESERVOIRS

### Brakes

62 litre. 2 tanks mounted inboard  
 Suspension and auxiliary  
 54 litre. 2 tanks mounted inboard  
 Midland Berg triple action air dryer/oil filter

## WHEELS / TYRES

10-stud steel disc wheels 8.25 x 22.5"  
 PCD 335mm  
 Michelin XZU 3 Tyres 295/80 22.5

### Optional:

Aluminium disc wheels 8.25 x 22.5"

## CHASSIS

### DIMENSIONS (mm)

		Chassis	Chassis
Wheelbase	WB	5100	6200
Chassis length	OAL	10058	11800
Front overhang	FOH	2041	2400
Rear overhang	ROH	2912	3200
Front track		2013	2013
Rear track		1803	1830
Overall width		2403	2430
Frame height front	FHF	884	884
Frame height rear	FHR	919	919
Approach angle	AA	11°	11°
Departure angle	DA	7°	7°

### Weights (kg)

Front axle	6630	6630
Rear axle	11000	11000
GVM	17630	17630

### TO SUIT BODIES 10.9M TO 12.5M

## FRAME

Powder coated high strength, low alloy steel channel

## DRIVE / STEERING

Power steering, type Sheppard M110  
 Steering wheel: diameter 500 mm  
 Steering wheel lock on column

## ELECTRICAL SYSTEM

Rated supply voltage 24 V  
 Batteries 2 x N150 Capacity 800 CCA each  
 150 amp alternator

## COOLING SYSTEM

Engine and charge air cooler radiators located to the RHS of chassis. Thermostatically controlled fan with two speed magnetic on/off clutch drive  
 Capacity 51 litres

## INSTRUMENTATION

### Gauges

Fuel level, dual air pressure, engine water temp, electronic speedo & tachometer, odometer, engine hour meter, voltmeter and engine oil pressure  
 Warning lights  
 Battery charge, low air-pressure, turn indicator hazard lights, high beam, park brake, engine fault, automatic transmission fault, retarder on and fault, stop engine fault, wait to start, engine protection fault, low power steering fluid and cruise control on  
 Warning buzzer  
 Low air-pressure, low water level indicator, turn indicators, reverse gear

## OTHER STANDARD FEATURES

KAB air suspension drivers seat  
 Adjustable height and rake steering column  
 Fixed battery carrier and isolation switch  
 Rear mounted remote engine start/stop switch  
 Cruise control  
 Walnut finish to instrument surround  
 406mm Donaldson dry element engine air cleaner with remote mount restriction indicator

## PERFORMANCE

Top speed 100 Km/h with speed limiter

## FUEL TANK

300L tank located to the RHS  
 Self priming system