

ENGINE

Iveco **CURSOR 13**

Type: Turbocharged, aftercooled, electronically direct injected fourstroke diesel with cruise control and Iveco Turbo Brake (ITB).

Number of cylinders: 6.

RAC HP rating: 67.8.

Total displacement: 12.9 litres.

Maximum output: 485hp/357kW @ 1900rpm.

Maximum torque: 1622lb ft/2200Nm @ 1000rpm.

280mm dry-element air cleaner and single gantry-mounted exhaust. (LHS)

Optional:

Maximum output: 505hp/372kW @ 1900rpm.

Maximum torque: 1696lb ft/2300Nm @ 1000rpm.

Maximum output: 550hp/405kW @ 1900rpm.

Maximum torque: 1733lb ft/2350Nm @ 1000rpm.

TRANSMISSIONS

Iveco EuroTronic II I6AS260 IOD automated 16-speed overdrive.

Two-pedal operation with automatic or manual shift control and ABS brakes. (Rev: 13.07/10.81:1, 1st:14.12:1, 16th: 0.83:1)

All with oil cooler.

REAR AXLE

Meritor RT46-160GP

Capacity: 20.9 tonnes.

Ratios: 3.21, 3.42, 3.58,

Driver controlled differential locks.

REAR SUSPENSIONS

Hendrickson Primaax PAX 460

Type: Air.

Capacity: 18.0 tonnes.

CLUTCH

Self-adjusting single-plate with air assisted hydraulic actuation.

Diameter: 430mm.

FRONT AXLE

Iveco 5876

Type: Forged steel I-beam.

Capacity: 7.5 tonnes.

FRONT SUSPENSION

Type: Three-leaf parabolic springs.

Double acting telescopic shock absorbers.

Capacity: 7.0 tonnes.

BRAKES

Type: 2-circuit air system.

Front: Knorr ventilated disc brakes. Diameter 436mm. Pad area: 784cm².

Rear: Meritor S-Cam 419mm diameter x 178mm drum brakes with automatic slack adjusters.

Brake lining area: 5600cm².

100-litre aluminium air reservoirs.

Dessicant type air dryer/pressure regulator.

Semi-trailer air connections and hand control valve.

Wabco E 4-channel ABS/EBL

Trailer ABS facility.

Optional:

Wabco E 4-channel ABS with ASR. (not available with Meritor AC-6S)

STEERING

ZF 8098 power-assisted with gear-driven pump.
460mm diameter adjustable steering wheel.

FUEL SYSTEM

Aluminium tanks.

2 x 450 litres.

Fuel Pro primary filter.

Optional:

450 litres + 200 litres fuel/250 litres oil.

Supplementary 2 x 360l tanks.

CHASSIS

Type: 257x89x8mm parallel-section high-tensile steel channel.

Yield strength: 760 MPa.

Section modulus: 243cm³.

FRP painted airdam bumper.

Tapered rear of frame with fifth wheel mounting angles.

Optional:

Square end of frame.

Deckplate.

Bocar Polished aluminium bull bar.

ELECTRICAL SYSTEM

Type: 24-Volt, negative to earth.

Multiplex computerized CANBUS integrated wiring and systems control network with centralised colour display, controls and diagnostics.

Batteries: 4 x 560 amps SAE cold cranking current per battery, with remote isolation switch mounted behind cab.

Alternator: 24V, 90 amps.

Headlamps: 70/75 watt, with covers.

Rear flood light.

Semi-trailer HD ISO 7-pin socket.

12 Volt power outlet in dash.

Cab marker lights.

Trailer connections.

24-12 Volt converter for trailer lighting.

70 Watt fog and driving lamps with covers.

Tail light brackets and mudflaps.

WHEELS AND TYRES

Wheels: 8.25DC x 22.5 10-stud 335mm steel disc.

Front tyres: Michelin XZE2+ 295/80R22.5

Rear: Michelin XDE2 11R22.5

Spare: Wheel without tyre.

Optional:

Alcoa 8.25DC x 22.5 10 stud 335mm PCD alloy disc. Unpolished or Durabright finish.

COOLING SYSTEM

Radiator frontal area: 8400cm².

Charge air cooler frontal area: 5700cm².

Two-speed electronic magnetic fan controlled by engine ECM and mux system.

DRIVELINE

Spicer 1810 Series main driveline with Spicer 1710 Series interaxle.

CAB Construction

Iveco ActiveTime 2280mm wide, all steel, conventional control sleeper cab with low roof.
Four-point cab mounting system with air suspension and dampers at rear.

Features

Active Time sleeper bunk with 2090mm x 715mm lower sleeper bunk with 150mm thick mattress. Privacy curtains for windows and bunk area. Lockers below lower bunk with access from cab and external access door lh sides. External stowage lockers under sleeper both sides. Stowage lockers in overhead console above windscreen. Fully adjustable ISRI self levelling air suspension driver's seat with headrest, adjustable shock absorber and integral lap-sash retractor seat belt. Fixed passenger seat with lap sash retractor seat belt. 90° opening doors with electrically operated window and low-level visibility forward window.

Accessories

Two internal sun visors with shade cloth blinds on side window. Dark grey acrylic exterior sunvisor. Aerodynamic powered and heated mirrors, with a flat and convex spotter mirror on each side and a kerb view mirror on the passenger side. Climate control Air conditioning. Heater demister with 4-speed fan. Demist ducts to door glasses. 2-speed and intermittent action twin windscreen wipers/washers. AM/FM radio/CD player with steering wheel controls. Dual roof-mounted air horns. Iveco Colour Display (ICD) instrument panel with Electronic speedometer and tachometer; fuel level gauge, engine coolant temperature gauge, and ICD displays for air pressure, system voltage, engine oil level, pressure and temperature, engine coolant temperature. Warning lights in ICD for power divider, difflocks, park brake, engine brake, high beam, fog and driving lights, parking lights, turn signal, hazard lights, low air pressure, brake system fault, park brake, mirror heaters. The ICD also gives information on Hi-Fi settings and control, Clock and alarm settings, trip data and trip computer, diagnostics, mirror adjustments and Eurotronic transmission, functions. Air controls mounted in centre dash console for park brake, trailer brakes, inter-axle locks cross-diff locks and rear air suspension dump.

Finish

White painted cab and bumper with grey fenders. Cab treated with anti-corrosion protection and metallic joints treated with vinyl sealant. Anti scratch treatment on cab underbody.

Optional:

2090mm x 760mm lower sleeper bunk with 150mm thick mattress. Ventilation windows on both sides of sleeper cab. ISRI self levelling air suspension passenger seat with headrest, adjustable shock absorber and integral lap-sash retractor seat belt. Medium Roof sleeper with standing room height interior, including electrically operated clear sun roof hatch with blind, stowage lockers in front section of medium roof, and stowage bins in side of medium roof section. Upper bunk for medium roof sleeper. Dual band VHF / UHF CB radio. Aerodynamic roof deflectors and cab side extenders.

MASS RATINGS

GVM 24.5 tonnes.
GCM 75.0 tonnes.
Optional GCM* 90.0 tonnes

Chassis mass front: 4.22 tonnes
Chassis mass rear: 3.39 tonnes
Chassis mass total: 7.61 tonnes
Chassis with RT40-160GP axles, oil and coolant, but no fuel, spare wheel or tyre.

*Suitably rated engine, transmission and suspension components are required.

SUSPENSION (dimensions in mm)

	B	C	D Laden	D Unladen	E
PAX460	658	665	1005	1030	105

CHASSIS DIMENSIONS (dimensions in mm)

WB	4800	5000	5250
GC(Front)	273	273	273
GC(Rear)	242	242	242
AF	1370	1370	1750
CA	2045	2245	2495
CF	3415	3615	4245
L	7480	7680	8220
Turning circle**	17200	17900	18800

** For wall to wall, add 850mm

Cab Style (dimensions in mm)

	H	H w aerokit
Low Roof Sleeper	2980	4000
Medium Roof Sleeper	3615	4000

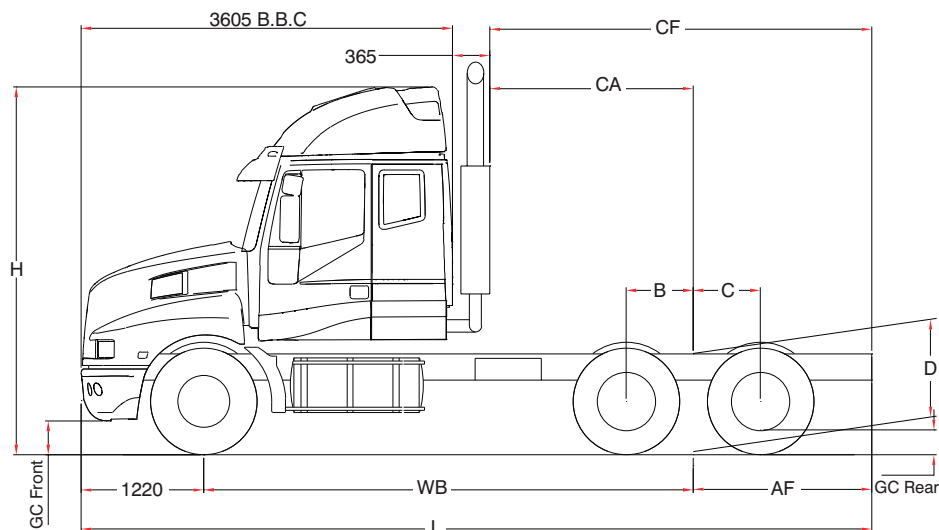

IVECO