

ENGINE

IVECO Cursor E4
SCR (Selective Catalytic Reduction)
Type: Turbo charged, after-cooled, electronically direct injected four stroke diesel with IVECO Turbo Brake (ITB).
Number of cylinders: 6.
RAC HP rating: 67.8
Total displacement: 12.9 litres.
Maximum output: 450hp/336kw @ 1900rpm.
Maximum torque: 1622lb ft/2200Nm @1000rpm.
Dry-element air cleaner and gantry-mounted exhaust (LHS) with vertical catalytic muffler.
Optional:
500hp/373kW.
1696lb ft/2300Nm.
560hp/418kW.
1840lb ft/2495Nm.

TRANSMISSION

IVECO EuroTronic II I6AS2630 TO OD automated 16-speed overdrive.
Two-pedal operation with automatic or manual shift control.
(Rev: 13.07/10.81:1, 1st:14.12:1, 16th: 0.83:1)
With oil cooler.

REAR AXLE

Meritor RT46-160GP
Capacity: 20.9 tonnes.
Ratios: 3.58, 3.73, 4.10.
Driver controlled differential locks.
Optional:
Meritor RT50-160GP (560HP Prime Mover only).

REAR SUSPENSION

Hendrickson Primaax PAX 460
Type: Air.
Capacity: 18.0 tonnes.

CLUTCH

Self-adjusting single-plate with air assisted hydraulic actuation.
Diameter: 430mm.

FRONT AXLE

IVECO 5876
Type: Forged steel I-beam.
Capacity: 7.5 tonnes.

FRONT SUSPENSION

Type: Three-leaf parabolic springs.
Double acting telescopic shock absorbers.
Capacity: 7.0 tonnes.

BRAKES

Type: 2-circuit air system.
Front: 432mm Knorr disc brakes.
Rear: Meritor S-Cam 419mm diameter x 178mm drum brakes with automatic slack adjusters.
Brake lining area: 5600cm².
Optional:
Knorr SN7 Rear Disc Brakes on rear axles.
100-litre aluminium air reservoirs.
Dessicant type air dryer/pressure regulator.
Semi-trailer air connections.
Wabco E 4-channel ABS/EBL with ASR.
Trailer ABS facility.

STEERING

ZF 8098 power-assisted with gear-driven pump.
460mm diameter adjustable steering wheel.

FUEL SYSTEM

Aluminium tanks.
2 x 450 litres of fuel = 900 litres.
1 x 100 litres AdBlue.
Fuel Pro primary filter.
Optional:
450 litres + 200 litres fuel/250 litres oil = 650 litres.
2 x 450 litres + 360 litres + 240 litres = 1500 litres.
(Prime Mover only).

CHASSIS

Type: 257 x 89 x 8mm parallel-section high-tensile steel channel.
Yield strength: 760 MPa.
Section modulus: 243cm³.
FRP painted airdam bumper. (No FUPD)
Tapered rear of frame with fifth wheel mounting angles.
Optional:
Square end of frame with trailer connections to ROF.
Deckplate.
Polished aluminium bull bar with Fog and Driving lights, covers & FUPD.
Polished Alloy Bumper with Fog and Driving lights, covers & FUPD.

ELECTRICAL SYSTEM

Type: 24-Volt, negative to earth.
Multiplex computerised CANBUS integrated wiring and systems control network with centralised colour display, controls and diagnostics.
Batteries: 4 x 560 amps SAE cold cranking current per battery, with remote isolation switch mounted behind cab.
Alternator: 24V, 90 amps.
Headlamps: 70/75 watt, with covers.
Rear flood light.
Semi-trailer HD ISO 7-pin socket.
12 Volt power outlet in dash.
Cab marker lights.
Trailer connections.
24-12 Volt converter for trailer lighting.
70 Watt fog and driving lamps with covers.
Tail light brackets and mudflaps.

WHEELS AND TYRES

Wheels: 8.25DC x 22.5 10-stud 335mm steel disc.
Front tyres: Michelin* XZE2, 295/80R22.5
Rear: Michelin* XDE2, 11R22.5
Spare: Wheel without tyre.
Optional:
Alcoa 8.25DC x 22.5 10 stud 335mm PCD alloy disc.
Plain or Durabright finish.
**or different brand, equivalent model.*

COOLING SYSTEM

Radiator frontal area: 8400cm².
Charge air cooler frontal area: 5700cm².
Two-speed electronic magnetic fan, controlled by VCM and Mux system.

DRIVELINE

Spicer 1810 Series main driveline with Spicer 1710 Series interaxle.

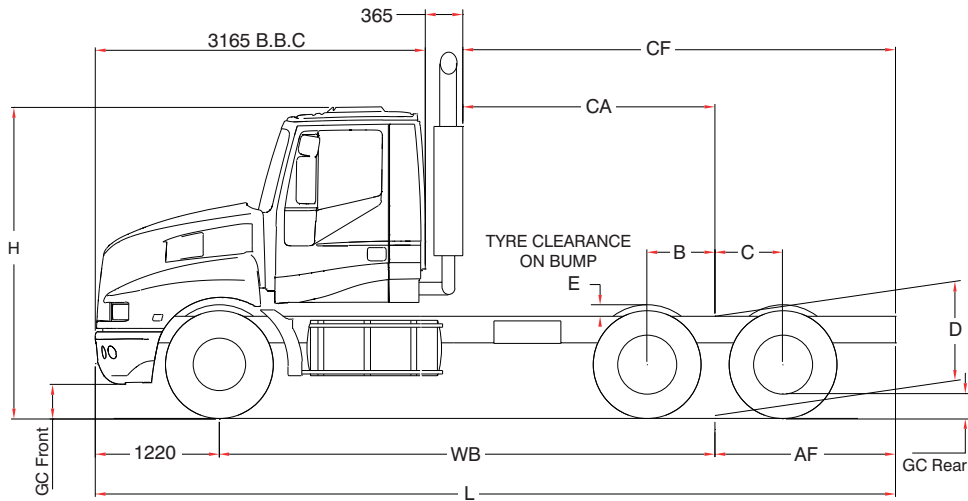

CAB CONSTRUCTION

IVECO Active Day 2280mm wide, 3165mm BBC all steel, conventional control day cab with low roof. Four-point cab mounting system with air suspension and dampers at rear.

FEATURES

Fully adjustable ISRI self levelling air suspension driver's seat with headrest, adjustable damper and integral lap-sash retractor seat belt. Fixed ISRI passenger seat with lap sash retractor seat belt. 90° opening doors with electrically operated window and low-level visibility forward window. Storage locker in overhead console and compartments on left hand door and rear wall of cab.

ACCESSORIES

Two internal sun visors with shade cloth blinds on side window. Dark grey acrylic exterior sunvisor. Aerodynamic powered and heated mirrors, with a flat and convex spotter mirror on each side and a kerb view mirror on the passenger side. Climate control Air conditioning. Heater demister with 4-speed fan. Demist ducts to door glasses. 2-speed and intermittent action twin windscreen wipers/washers. AM/FM radio/CD player with steering wheel controls. Dual roof-mounted air horns. Iveco Colour Display (ICD) instrument panel with Electronic speedometer and tachometer, fuel level gauge, engine coolant temperature gauge, and ICD displays for air pressure, system voltage, engine oil level, pressure and temperature, engine coolant temperature. Warning lights in ICD for power divider, difflocks, park brake, engine brake, high beam, fog and driving lights, parking lights, turn signal, hazard lights, low air pressure, brake system fault, park brake, mirror heaters. The ICD also gives information on Hi-Fi settings and control, clock and alarm settings, trip data and trip computer, diagnostics, mirror adjustments and Eurotronic transmission functions. AdBlue level. Air controls mounted in centre dash console for park brake, inter-axle locks cross-diff locks and rear air suspension dump. Gear control lever on steering column. Cruise control.

Optional:

ISRI self levelling air suspension passenger seat with headrest, adjustable shock absorber and integral lap-sash retractor seat belt. Aerodynamic roof deflectors and cab side extenders.

FINISH

White painted cab and bumper with grey fenders. Cab treated with anti-corrosion protection and metallic joints treated with vinyl sealant Insulation on cab underbody.

MASS RATINGS

GVM 24.5 tonnes.
GCM 65.0 tonnes.
Optional: GCM* 90.0 tonnes.

Chassis mass front 4.46 tonnes
Chassis mass rear 3.85 tonnes
Chassis mass total 8.31 tonnes
Chassis with RT46-160GP axles, oil and coolant, but no fuel, spare wheel or tyre.

*Suitably rated engine, transmission and suspension components are required.

SUSPENSION (Dimensions in mm)

	B	C	D Laden	D Unladen	E
PAX460	658	665	1005	1030	105

CHASSIS DIMENSIONS (Dimensions in mm)

WB	4800	5000 (Tipper)
GC(Front)	273	273
GC(Rear)	242	242
AF	1420	1800
CA	2490	2690
CF	3910	4490
L	7440	8020
Turning circle**	17200	17900

**For wall to wall, add 850mm

CAB (Dimensions in mm)

	H	H (aero kit)
Low roof sleeper	2980	4000

IVECO Trucks Australia Limited

A.B.N. 86 004 065 061
Princes Hwy, Dandenong, Victoria 3175
P.O. Box 117 Dandenong, Victoria 3175
Telephone: (03) 9238 2200
Facsimile: (03) 9238 2387
www.iveco.com.au

Powerstar Spec Sheet (AUGUST 2009)