

EUROCARGO

SPECIFICATION SHEET

MLI20E24 & E28



IVECO

EUROCARGO

MLI20E24 & E28

CHASSIS

Type: bolted and riveted parallel channel.
Size: 240 x 70 x 6.7 mm external.
Width: 850 mm
Yield strength: 420 MPa.
Heavy-duty front tow hook.

ENGINE

Iveco: Tector F4A E24.
Type: Turbocharged and intercooled 24-valve four-stroke diesel with high-pressure common-rail electronic injection.
Number of cylinders: 6
Displacement: 5.88 litres
Bore x stroke: 102 x 120 mm
Compression ratio: 17:1
Maximum output: 176 kW (240 hp) @ 2700 rpm
Maximum torque: 810 Nm (600 lb/ft) @ 1250-2100 rpm
Governed speed: 2700 rpm
RAC hp rating: 38.7
Oil capacity: 11.6 litres
Oil change intervals: up to 60,000 km (Subject to conditions)
Emissions standard: ADR 80/00
Optional: Tector F4A E28
Maximum output: 202 kW (280 hp) @ 2500 rpm
Maximum torque: 930 Nm (689 lb/ft) @ 1250-2100 rpm
Governed speed: 2500 rpm

CLUTCH

Type: Single-plate asbestos-free pull type with air over hydraulic assistance.
Diameter: 350 mm.
Lining area: 582 cm².

TRANSMISSION

Eaton: FSO 5206B six-speed overdrive synchromesh transmission.

| | |
|---------|--------|
| 1st | 6.08:1 |
| 2nd | 3.53:1 |
| 3rd | 2.09:1 |
| 4th | 1.35:1 |
| 5th | 1.00:1 |
| 6th | 0.79:1 |
| Reverse | 5.43:1 |

PTO: Rearwards position.
Optional: Iveco 2895.9 nine-speed direct-drive synchromesh transmission with double H-pattern (in conjunction with 280 hp version).

| | |
|--------------|---------|
| Crawler gear | 13.55:1 |
| 1st | 9.00:1 |
| 2nd | 6.55:1 |
| 3rd | 4.77:1 |
| 4th | 3.55:1 |
| 5th | 2.54:1 |
| 6th | 1.85:1 |
| 7th | 1.34:1 |
| 8th | 1.00:1 |
| Reverse | 13.16:1 |

PTO: Positions two.

REAR AXLE

Meritor MS10-144.
Type: Single-reduction fully-floating banjo type.
Differential lock.
Capacity: 8500 kg
Ratio: 4.11:1
Optional: Ratio: 3.42:1 (in conjunction with 280 hp version).

FRONT AXLE

Iveco 5842
Type: I-beam with oil-filled hubs.
Capacity: 4400 kg

STEERING

Type: Integral power-assisted circulating ball with gear-driven pump and integral reservoir.
Ratio: 20.4
Tilt-adjustable 465 mm diameter steering wheel. Angular 10°.
Vertical 40 mm.

FRONT SUSPENSION

Type: Parabolic.
Parabolic springs with dual-action hydraulic shock absorbers and stabiliser bar fitted.
1714 x 70 x 23 mm two-leaf.
Optional: Air bag
Two bellows, front air suspension with dual-action hydraulic shock absorbers and stabiliser bar.

REAR SUSPENSION

Type: Air bag
Quad bellows, rear air bag suspension with dual-action hydraulic shock absorbers and stabiliser bar.
ECAS Electronically Controlled Air Suspension including dual-rear levelling valves.
Remote-control operation complete with memory function.

BRAKES

Type: Full air-brake system with two independent circuits.
377 x 45 mm ventilated front/rear disc brakes with floating calipers (asbestos free).
ABS: Three-channel system.
Spring-actuated park brake acting on rear wheels.
Exhaust brake (three mode).
Air dryer:
360 cc air compressor (water cooled).

FUEL SYSTEM

Nominal tank capacity: 280 litres.
Fuel prefilter with water separator fitted to chassis.

ELECTRICAL

Type: 24V negative to earth.
24V-12V converter in cab.
Alternator capacity: 28V, 90 amp.
Starter: 24V, 4.0 kW.
Battery: 2 x 12V 110 Ah.
Automatic battery isolation switch.

WHEELS AND TYRES

Wheels: One-piece steel disc rims.
Stud and pattern: M22, 8 x 275 mm PCD.
Disc size: 19.5" x 6.75".
Tyres: Michelin 265/70R19.5 tubeless radial.
Tyre minimum rating: 136/134M.
Spare located on left-hand side.

CAB

Type: Forward-control (MLC) day cab.
Construction: Pressed two-side zinc-coated steel on selected outer panels with Electro-cataphoretic corrosion protection. SMC front panels and fenders.
Four-point cab suspension.
Front: Two coil springs, shock absorbers and torsion bar.
Rear: Two McPherson units with coils springs.
Hydraulic cab tilt to 60°.

EUROCARGO

MLI20E24 & E28

Features

Front underrun protection.
 External sunvisor.
 Lift-up front panel for daily checks.
 Fully-adjustable Isringhausen driver's air-suspension seat with headrest.
 Dual bench-passenger seat with fold-down central oddments tray.
 2 x lap-sash seat belts for outboard positions, 1 x lap seat belt for centre position.
 AM/FM radio CD player (Dealer fitment).
 90-degree opening doors
 Stowage compartment in overhead console, both doors and rear cab wall.
 2-speed wipers with intermittent control.
 Courtesy and map lamps.
 Electric horn.
 12-volt power socket (10 amp).
 Electrically operated drive and passenger side windows.
 Aerodynamic, remote-control heated mirrors with a flat mirror on the right-hand side, a convex, spotter and over-the-kerb mirror on the left-hand side.
 Air conditioning.
 Cruise control.
Optional: (MLL) sleeper cabin.
 ADR-compliant, fully-finished sleeper cab with mattress, curtains, reading lamp, roof hatch and one internal and one external locker.
 Bunk dimensions: 1900 x 605 x 95 mm.

Instrumentation

Electronic anti-glare instrument panel.
 Gauges: Speedometer; odometer with trip meter; tachometer; water temperature, fuel level, oil pressure and air pressure.

Warning lamps: Power-steering circuit failure, front and rear brake wear; high water temperature, air-cleaner restriction, cab unlatched, low alternator charge, high beam, exterior lights on, hazard warning lights on, low oil pressure, reserve fuel, park brake on, water in pre-filter; brake system failure.

LCD information panel: System diagnostics, lighting system check, programmable maintenance scheduling, digital clock, trip 1&2 computer; fuel consumption indicator; status and driver actuation information and ambient temperature.

CHASSIS DIMENSIONS (All dimensions in mm)

| Cab | Day | Sleeper |
|-----------------|-------|---------|
| H | 2682 | 2682 |
| W | 2325 | 2325 |
| WB | 5670 | 5670 |
| AF | 3000 | 3000 |
| CF | 8405 | 7825 |
| AC | 265 | 845 |
| L | 9960 | 9960 |
| Turning circle# | 18700 | 18700 |
| U | 179 | 179 |

#Wall-to-wall.

RATED SPEED

| | (E24 engine) | (E28 engine) |
|---------------------|--------------|--------------|
| Engine rpm @ 100kph | 2056rpm | 2166rpm |
| Geared speed | 131kph | 116kph |

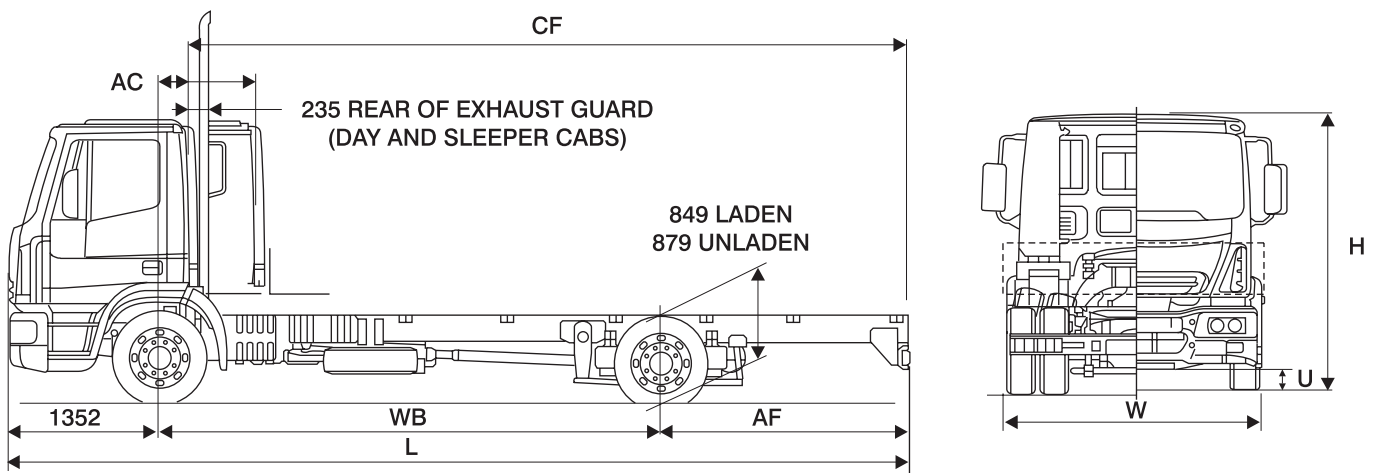

AVAILABLE CONFIGURATIONS

| Engine | Trans | W/base | Cabin | Suspension | | Batteries | Model Code | |
|------------|--------|---------|---------|-------------|-----------|-----------|------------|--------------|
| | | | | Front | Rear | | | |
| MLI20E24P | 240 hp | 6-speed | 5670 mm | MLC day | Parabolic | Air bag | 110 Ah | AI E 02 9A09 |
| MLI20E24P | 240 hp | 6-speed | 5670 mm | MLL sleeper | Parabolic | Air bag | 110 Ah | AI E 02 9B09 |
| MLI20E28FP | 280 hp | 9-speed | 5670 mm | MLL sleeper | Air bag | Air bag | 170 Ah | AI EM02 9B06 |

EUROCARGO TARE WEIGHTS

| | Cab | Wheelbase | Front tare | Rear tare | Total tare | GVM | GCM |
|------------|---------|-----------|------------|-----------|------------|---------|---------|
| MLI20E24P | Day | 5670 mm | 3027 kg | 1648 kg | 4675 kg | 12000kg | 18000kg |
| MLI20E24P | Sleeper | 5670 mm | 3111 kg | 1652 kg | 4763 kg | 12000kg | 18000kg |
| MLI20E28FP | Sleeper | 5670 mm | 3198 kg | 1721 kg | 4919 kg | 12000kg | 24000kg |

All weights with oil, coolant, spare wheel and tyre but not fuel. Subject to manufacturer's tolerance of + or -2%.



MLI20E24 & E28

Important

The illustrations and specifications ("material") in this brochure were correct at the time of publication but are subject to change without notice. The material is provided by way of general description only and all measurements and specifications should be regarded as approximate. Availability of vehicles and all other items referred to in this brochure will depend on local and overseas supply conditions from time to time. Accordingly, before placing an order you should consult your nearest authorised Iveco dealer to obtain accurate and up-to-date information on models specifications, features, availability and prices.

IVECO

**Iveco Trucks
Australia Limited**

ABN 86 004 065 061

Princes Hwy,
Dandenong Victoria 3175

www.iveco.com.au

email: iveco@iveco.com.au

The information in this literature is intended to be of general nature only. Iveco reserves the right to modify or change specifications at any time. For more detailed information refer to your dealer.