

**ENGINE**

IVECO Cursor E5

SCR (Selective Catalytic Reduction)

**Type:** Turbo charged, after-cooled, electronically direct injected four stroke diesel with IVECO Turbo Brake (ITB)**Number of cylinders:** 6**RAC HP rating:** 67.8**Total displacement:** 12.9 litres**Maximum output:** 450hp/336kw @ 1900rpm**Maximum torque:** 1622lb ft/2200Nm @1000rpm

Dry-element air cleaner and gantry-mounted exhaust (LHS) with vertical catalytic muffler

**Optional:**

500hp/373kW

1696lb ft/2300Nm

560hp/418kW

1840lb ft/2495Nm

**TRANSMISSION**

IVECO EuroTronic II 16AS2630 TO OD automated 16-speed overdrive

Two-pedal operation with automatic or manual shift control

(Rev: 13.07/10.81:1, 1st:14.12:1, 16th: 0.83:1)

With oil cooler

**REAR AXLE**

Meritor RT46-160GP

**Capacity:** 20.9 tonnes**Ratios:** 3.58, 3.73, 4.10

Driver controlled differential locks

**Optional:**

Meritor RT50-160GP (560HP Prime Mover only)

**REAR SUSPENSION**

Hendrickson Primaax PAX 460

**Type:** Air**Capacity:** 18.0 tonnes**CLUTCH**

Self-adjusting single-plate with air assisted hydraulic actuation

**Diameter:** 430mm**FRONT AXLE**

IVECO 5876

**Type:** Forged steel I-beam**Capacity:** 7.5 tonnes**FRONT SUSPENSION****Type:** Three-leaf parabolic springs

Double acting telescopic shock absorbers

**Capacity:** 7.0 tonnes**BRAKES****Type:** 2-circuit air system**Front:** 432mm Knorr disc brakes**Rear:** Meritor S-Cam 419mm diameter x 178mm drum brakes with automatic slack adjusters**Brake lining area:** 5600cm<sup>2</sup>**Optional:**

Knorr SN7 Rear Disc Brakes on rear axles

100-litre aluminium air reservoirs

Dessicant type air dryer/pressure regulator

Semi-trailer air connections

Wabco E 4-channel ABS/EBL with ASR

Trailer ABS facility

**STEERING**

ZF 8098 power-assisted with gear-driven pump

460mm diameter adjustable steering wheel

**FUEL SYSTEM**

Aluminium tanks.

2 x 450 litres of fuel = 900 litres

1 x 100 litres AdBlue

Fuel Pro primary filter

**Optional:**

450 litres + 200 litres fuel/250 litres oil = 650 litres

2 x 450 litres + 360 litres + 240 litres = 1500 litres

(Prime Mover only)

**CHASSIS****Type:** 257 x 89 x 8mm parallel-section high-tensile steel channel**Yield strength:** 760 MPa**Section modulus:** 243cm<sup>3</sup>

FRP painted airdam bumper: (No FUPD)

Tapered rear of frame with fifth wheel mounting angles

**Optional:**

Square end of frame with trailer connections to ROF

Deckplate

Polished aluminium bull bar with Fog and

Driving lights, covers &amp; FUPD

Polished Alloy Bumper with Fog and Driving lights, covers &amp; FUPD

**ELECTRICAL SYSTEM****Type:** 24-Volt, negative to earth.

Multiplex computerised CANBUS integrated wiring and systems control network with centralised colour display, controls and diagnostics

**Batteries:** 4 x 560 amps SAE cold cranking current per battery, with remote isolation switch mounted behind cab**Alternator:** 24V, 90 amps**Headlamps:** 70/75 watt, with covers

Rear flood light

Semi-trailer HD ISO 7-pin socket

12 Volt power outlet in dash

Cab marker lights

Trailer connections

24-12 Volt converter for trailer lighting

70 Watt fog and driving lamps with covers

Tail light brackets and mudflaps

**WHEELS AND TYRES****Wheels:** 8.25DC x 22.5 10-stud 335mm steel disc**Front tyres:** Michelin\* XZE2, 295/80R22.5**Rear:** Michelin\* XDE2, 11R22.5**Spare:** Wheel without tyre**Optional:**

Alcoa 8.25DC x 22.5 10 stud 335mm PCD alloy disc

Plain or Durabright finish

\*or different brand, equivalent model

**COOLING SYSTEM****Radiator frontal area:** 8400cm<sup>2</sup>**Charge air cooler frontal area:** 5700cm<sup>2</sup>

Two-speed electronic magnetic fan, controlled by VCM and Mux system

**DRIVELINE**

Spicer 1810 Series main driveline with Spicer 1710 Series interaxle

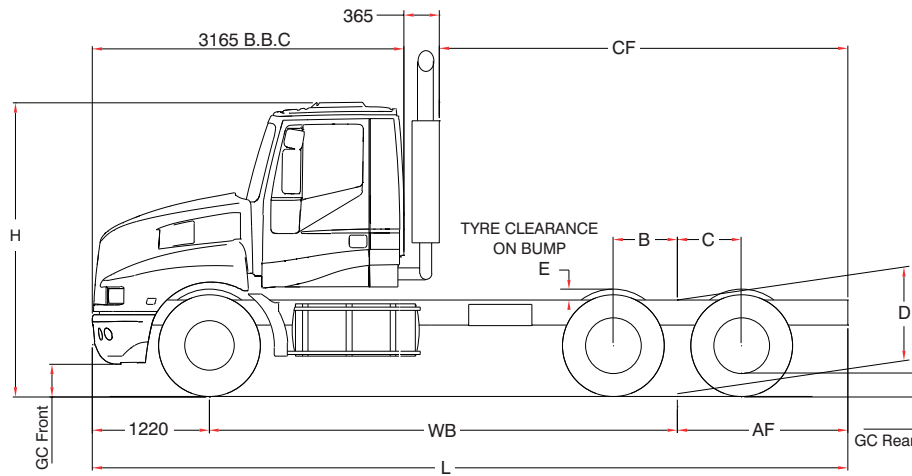

### CAB CONSTRUCTION

IVECO Active Day 2280mm wide, 3165mm BBC all steel, conventional control day cab with low roof.  
Four-point cab mounting system with air suspension and dampers at rear.

### FEATURES

Fully adjustable ISRI self levelling air suspension driver's seat with headrest, adjustable damper and integral lap-sash retractor seat belt. Fixed ISRI passenger seat with lap sash retractor seat belt. 90° opening doors with electrically operated window and low-level visibility forward window. Storage locker in overhead console and compartments on left hand door and rear wall of cab.

### ACCESSORIES

Two internal sun visors with shade cloth blinds on side window. Dark grey acrylic exterior sunvisor. Aerodynamic powered and heated mirrors, with a flat and convex spotter mirror on each side and a kerb view mirror on the passenger side. Climate control Air conditioning. Heater demister with 4-speed fan. Demist ducts to door glasses. 2-speed and intermittent action twin windscreen wipers/washers. AM/FM radio/CD player with steering wheel controls. Dual roof-mounted air horns. Iveco Colour Display (ICD) instrument panel with Electronic speedometer and tachometer, fuel level gauge, engine coolant temperature gauge, and ICD displays for air pressure, system voltage, engine oil level, pressure and temperature, engine coolant temperature. Warning lights in ICD for power divider, difflocks, park brake, engine brake, high beam, fog and driving lights, parking lights, turn signal, hazard lights, low air pressure, brake system fault, park brake, mirror heaters.

The ICD also gives information on Hi-Fi settings and control, clock and alarm settings, trip data and trip computer, diagnostics, mirror adjustments and Eurotronic transmission functions.

AdBlue level. Air controls mounted in centre dash console for park brake, inter-axle locks cross-diff locks and rear air suspension dump. Gear control lever on steering column. Cruise control.

#### Optional:

ISRI self levelling air suspension passenger seat with headrest, adjustable shock absorber and integral lap-sash retractor seat belt. Aerodynamic roof deflectors and cab side extenders.

### FINISH

White painted cab and bumper with grey fenders. Cab treated with anti-corrosion protection and metallic joints treated with vinyl sealant Insulation on cab underbody.

### MASS RATINGS

GVM 24.5 tonnes  
GCM 65.0 tonnes  
Optional: GCM\* 90.0 tonnes

Chassis mass front 4.46 tonnes  
Chassis mass rear 3.85 tonnes  
Chassis mass total 8.31 tonnes  
Chassis with RT46-160GP axles, oil and coolant, but no fuel, spare wheel or tyre.

*\*Suitably rated engine, transmission and suspension components are required.*

### SUSPENSION (Dimensions in mm)

	B	C	D Laden	D Unladen	E
PAX460	658	665	1005	1030	105

### CHASSIS DIMENSIONS (Dimensions in mm)

WB	4800	5000 (Tipper)
GC (Front)	273	273
GC (Rear)	242	242
AF	1420	1800
CA	2490	2690
CF	3910	4490
L	7440	8020
Turning circle**	17200	17900

*\*\*For wall to wall, add 850mm*

### CAB DIMENSIONS (Dimensions in mm)

	H	H (aero kit)
Low roof sleeper	2980	4000

**IVECO Trucks Australia Limited** A.B.N. 86 004 065 061

Princes Hwy, Dandenong, Victoria 3175

P.O. Box 117 Dandenong, Victoria 3175

Telephone: (03) 9238 2200 Facsimile: (03) 9238 2387

[www.iveco.com.au](http://www.iveco.com.au)