

ENGINE

IVECO FIC 3.0l - 4 stroke diesel with direct-injection, turbocharger and intercooler. Water-cooled with electromagnetic fan. Cast-iron engine block with aluminium cylinder head. New generation common rail injection system. Exhaust gas recirculation system - EGR. Exhaust system with diesel particulate filter (CRT - Continuously Regenerating Trap) and muffler longitudinally positioned on the right side and stub-pipe located mid-way down right side of vehicle.

Basic data

| | |
|---------------------|---------------------------------|
| Number of cylinders | 4 (16 valves) vertical in line. |
| Bore x stroke | 95.8 mm x 104 mm. |
| Total displacement | 2998 cm ³ |
| Engine | 3.0 HPT* |
| Power (hp/Kw) | 176/130 |
| At rpm: | 3200-3500 |
| Torque (Nm/lbft) | 400/295 |
| At rpm: | 1250-3000 |

*HPT: High Performance Turbine with VGT – Variable Geometry Turbo

FRAME

C Section steel longitudinal side members with tapered ends and tubular cross members.

| | | |
|----------------------------|------|------|
| Wheelbase (mm) | 3750 | 4350 |
| Cross members | 6 | 7 |
| Side member height (mm) | 182 | 182 |
| Side member width (mm) | 70 | 70 |
| Side member thickness (mm) | 4 | 4 |

TRANSMISSION

Six speed synchromesh overdrive manual transmission.

Type: 6S400 OD.

| | |
|---------|-------|
| 1st | 5.373 |
| 2nd | 3.154 |
| 3rd | 2.041 |
| 4th | 1.365 |
| 5th | 1.000 |
| 6th | 0.791 |
| Rev.1st | 4.838 |

Optional transmission automated: AGile

Six speed synchromesh overdrive automated transmission.

Type: 6AS400.

| | |
|---------|-------|
| 1st | 5.373 |
| 2nd | 3.154 |
| 3rd | 2.041 |
| 4th | 1.365 |
| 5th | 1.000 |
| 6th | 0.791 |
| Rev.1st | 4.838 |

CLUTCH

Single dry plate.

Hydraulically controlled.

External diameter: 280 mm (11").

AXLES

Front: IVECO 5819 independent, 1900 kg capacity.

Rear: IVECO 450511 full-floating single reduction, 3700 kg capacity.

Rear axle ratio: 3.91:1

Optional (1):

Rear axle ratio: 4.18:1 for fifth wheel application (Normal Duty).

Optional (2):

Rear axle ratio: 4.44:1 for fifth wheel application (Heavy Duty).

SUSPENSION

Front: Independent with adjustable torsion bar anchored to the chassis integrated with double-acting telescopic shock absorbers and anti-roll bar.

Rear: Multileaf spring, rubber rebound bump stops, heavy duty shock absorbers and anti-roll bar.

LIGHTING & SIGNALING SYSTEM

Halogen headlamps; twin front and rear fog lamps and twin reverse lamps.

WHEELS / TYRES

Tyres: 195/75 R16.

Wheels: 5JK 16H1.

ELECTRICAL SYSTEM

Battery: 12V - 110 Ah.

Alternator: 12V - 140 A.

Trailer wiring to rear of chassis.

BRAKING SYSTEM

ABS 8 with EBD - Electronic Brake force Distribution.

Front / Diameter Ventilated disc brakes / 290 mm.

Rear / Diameter Disc brakes / 290 mm.

Parking brake Manual brake operating on rear axle.

Service brakes:

Dual circuit with vacuum servo.

Pad wear warning light for front and rear brakes.

STEERING

Power steering. Steering wheel diameter 420 mm.

Three piece steering column with connecting universal joints.

OTHER EQUIPMENT

- Spare wheel carrier located under the rear overhang.

- 100 litres on nearside with locking fuel cap.

- Front tow hook.

CABIN

- Drivers airbag with seat belt pretensioners.

- Fully adjustable driver's seat with headrest.

- Three point inertia reel belt on all seats except on the rear middle seat.

- Dual passenger seats with headrests.

- Cruise control.

- Electric windows.

- Exterior mirror with integrated wide angle and direction indicators, heated and electrically adjustable.

- Overhead console with storage shelf and standard space for additional equipment.

- Large dual storage pockets in doors.

- Underseat storage.

- Document storage compartment.

- Insulated compartment located on the dashboard.

- Body builders connectors.

- Single piece floor mat.

- 2 cup holders plus 1 bottle holder.

- Glove compartment with added storage.

- Additional in-dash storage.

- Clip holder.

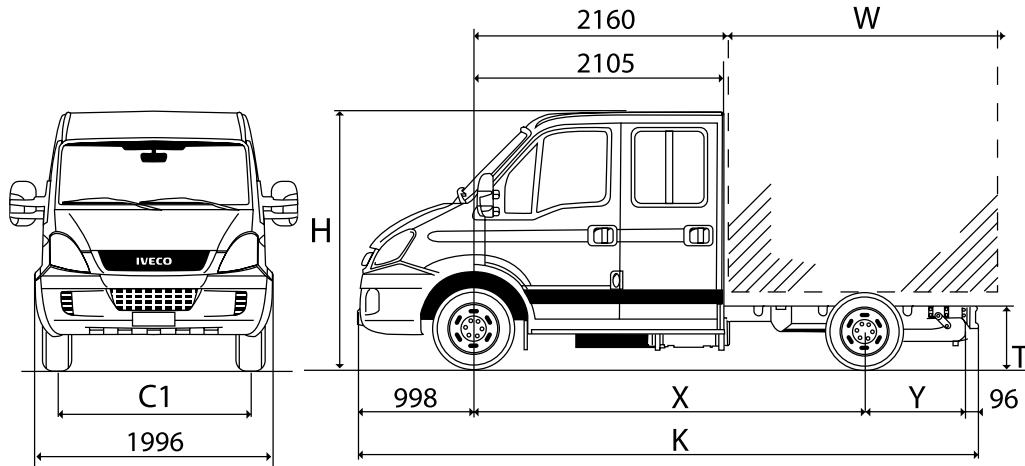

DASHBOARD

- New soft-feeling anti-reflective material.
- Analogue electronic speedometer.
- Electronic tachometer.
- Fuel level indicator with reserve light indicator.
- Coolant temperature indicator with high temperature indicator light.
- Instrument light dimmer switch.
- Dash-mounted gear lever.
- 3 DIN drawers, one of which carries CD Player.
- LCD Display Panel includes: odometer, trip computer with distance, time, fuel consumption etc; headlamp orientation (dip/main); clock, external temperature, service indicator, gear selected with the automated transmission (only on AGile).
- Stereo radio/CD player (with CAN security).

SECURITY

- Central locking with remote control and door locking management.
- Steering lock.
- Engine immobilizer actuated by transponder on ignition key.

CONSTRUCTION & FINISH

C-section steel longitudinal side members and tubular cross members with pressed steel unitary construction body mounted on rubber bushes. Anti-corrosion protection includes full catheporetic dipping with galvanized boxed sections and strategic use of zinc plated panels in vulnerable areas. Protective under seal for all under body cabin area, wheel housings and engine area. Polypropylene bumper and side mouldings.

CLIMATE CONTROL

Four speed electric fan with five different air distribution modes and cab recirculation. Windshield side window defroster and defogger through side and front fixed position air vents. Temperature-controlled air conditioned cab.

OPTIONS

- AGile - 6 speed automated transmission.
- Passenger airbags with seat belt tensioners plus side window airbags.
- ESP - Electronic Stability Programme (includes ASR - Traction control, MSR - Motor Torque Reduction, HBA - Hydraulic Brake Assist, HILL HOLDER).
- ECAS - Electronically Controlled Air Suspension on rear axle.
- Suspended and heated driver and passenger seats.

DIMENSIONS (mm)

| X | Wheelbase | 3750 | 4350 |
|----|------------------------------------|-------|-------|
| K | Overall length | 6538 | 7358 |
| H | Overall height (unladen) | 2290 | 2280 |
| C1 | Front track | 1696 | 1696 |
| | Rear track | 1541 | 1541 |
| | Unladen frame height at front axle | 586 | 583 |
| T | Unladen frame height at rear axle | 705 | 707 |
| | Front ground clearance | 196 | 196 |
| | Rear ground clearance | 177 | 177 |
| Y | Rear overhang | 1665 | 1885 |
| | Turning circle: kerb to kerb | 13400 | 16540 |
| | Turning circle: wall to wall | 14520 | 17660 |

BODY DIMENSIONS (mm)

| W | Maximum body length [#] | 3774 [#] | 4594 [#] |
|---|----------------------------------|-------------------|-------------------|
| | Maximum body width | 2350 | 2350 |

MASS (kg)

| GVM | 4495 | 4495 |
|--------------------------------------|-------------|-------------|
| | (opt. 5000) | (opt. 5000) |
| Towing capacity with braked trailer* | 3500* | 3500* |
| Front axle capacity | 1900 | 1900 |
| Rear axle capacity | 3700 | 3700 |
| Kerb mass front axle | 1515 | 1560 |
| Kerb mass rear axle | 750 | 730 |
| Kerb mass total | 2265 | 2290 |
| Body and payload capacity | 2230 | 2205 |
| | (opt. 2735) | (opt. 2710) |

*Subject to individual state regulations and requirements.

[#]Determined by legislative constraints and/or technical criteria for optional ride & handling. Kerb masses are with full fuel tank, oil, water, spare wheel, tools and include driver at 75 Kg. Maximum body width subject to mirror and lighting requirements.

IVECO Trucks Australia Limited

A.B.N. 86 004 065 061

Princes Hwy, Dandenong, Victoria 3175

P.O. Box 117 Dandenong, Victoria 3175

Telephone: (03) 9238 2200

Facsimile: (03) 9238 2387

www.iveco.com.au

EcoDaily Spec Sheet (November 2009)