

ENGINE

IVECO FIC 3.0I - 4 stroke diesel with direct-injection, turbocharger and intercooler. Water-cooled with electromagnetic fan. Cast-iron engine block with aluminium cylinder head. New generation common rail injection system. Exhaust gas recirculation system - EGR. Exhaust system with diesel particulate filter (CRT - Continuously Regenerating Trap) and muffler longitudinally positioned on the right side and stub-pipe located mid-way down right side of vehicle.

Basic data

Number of cylinders	4 (16 valves) vertical in line.
Bore x stroke	95.8 mm x 104 mm.
Total displacement	2998 cm ³
Engine	3.0 HPT*
Power (hp/Kw)	176/130
At rpm:	3200-3500
Torque (Nm/lbft)	400/295
At rpm:	1250-3000

*HPT: High Performance Turbine with VGT – Variable Geometry Turbo.

FRAME

C Section steel longitudinal side members with tapered ends and tubular cross members.

Wheelbase (mm)	3750	4350
Cross members	6	7
Side member height (mm)	184	184
Side member width (mm)	69	69
Side member thickness (mm)	5	5

TRANSMISSION

Six speed synchromesh overdrive manual transmission.

Type: 6S400 OD.

1st	5.373
2nd	3.154
3rd	2.041
4th	1.365
5th	1.000
6th	0.791
Rev.1st	4.838

Optional transmission automated: AGile

Six speed synchromesh overdrive automated transmission.

Type: 6AS400.

1st	5.373
2nd	3.154
3rd	2.041
4th	1.365
5th	1.000
6th	0.791
Rev.1st	4.838

CLUTCH

Single dry plate.

Hydraulically controlled.

External diameter: 280 mm (11").

AXLES

Front: IVECO 5823 independent, 2300 kg capacity.

Rear: IVECO 450517 full-floating single reduction, 5000 kg capacity.

Rear axle ratio: 4.30:1

Optional (1):

Rear axle ratio: 4.556:1 for fifth wheel application (Normal Duty).

Optional (2):

Rear axle ratio: 5.13:1 for fifth wheel application (Heavy Duty).

SUSPENSION

Front: Independent with adjustable torsion bar anchored to the chassis integrated with double-acting telescopic shock absorbers and anti-roll bar.

Rear: Multileaf spring, rubber rebound bump stops, heavy duty shock absorbers and anti-roll bar.

LIGHTING & SIGNALING SYSTEM

Halogen headlamps; twin front and rear fog lamps and twin reverse lamps.

WHEELS / TYRES

Tyres: 225/75 R16.

Wheels: 6JK 16H2.

ELECTRICAL SYSTEM

Battery: 12V - 110 Ah.

Alternator: 12V - 140 A.

Trailer wiring to rear of chassis.

BRAKING SYSTEM

ABS 8 with EBD - Electronic Brake force Distribution.

Front / Diameter Ventilated disc brakes / 301 mm.

Rear / Diameter Disc brakes / 306 mm.

Parking brake Manual brake operating on rear axle.

Service brakes:

Dual circuit with vacuum servo.

Pad wear warning light for front and rear brakes.

STEERING

Power steering. Steering wheel diameter 420 mm.

Three piece steering column with connecting universal joints.

OTHER EQUIPMENT

- Spare wheel carrier located under the rear overhang.

- 100 litres on nearside with locking fuel cap.

- Front tow hook.

CABIN

- Drivers airbag with seat belt pretensioners.

- Fully adjustable driver's seat with headrest.

- Three point inertia reel belt on all seats except on the rear middle seat.

- Dual passenger seats with headrests.

- Cruise control.

- Electric windows.

- Exterior mirror with integrated wide angle and direction indicators, heated and electrically adjustable.

- Overhead console with storage shelf and standard space for additional equipment.

- Large dual storage pockets in doors.

- Underseat storage.

- Document storage compartment.

- Insulated compartment located on the dashboard.

- Body builders connectors.

- Single piece floor mat.

- 2 cup holders plus 1 bottle holder.

- Glove compartment with added storage.

- Additional in-dash storage.

- Clip holder.

DAILY

65C18D DUAL CAB CHASSIS SPECIFICATIONS

IVECO

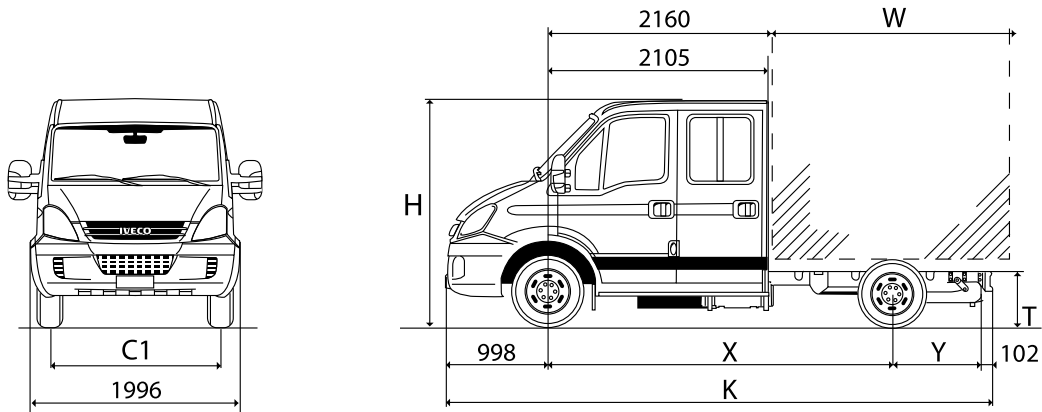

DASHBOARD

- New soft-feeling anti-reflective material.
- Analogue electronic speedometer.
- Electronic tachometer.
- Fuel level indicator with reserve light indicator.
- Coolant temperature indicator with high temperature indicator light.
- Instrument light dimmer switch.
- Dash-mounted gear lever.
- 3 DIN drawers, one of which carries CD Player.
- LCD Display Panel includes: odometer, trip computer with distance, time, fuel consumption etc; headlamp orientation (dip/main); clock, external temperature, service indicator, gear selected with the automated transmission (only on AGile).
- Stereo radio/CD player (with CAN security).

SECURITY

- Central locking with remote control and door locking management.
- Steering lock.
- Engine immobilizer actuated by transponder on ignition key.

CONSTRUCTION & FINISH

C-section steel longitudinal side members and tubular cross members with pressed steel unitary construction body mounted on rubber bushes. Anti-corrosion protection includes full cathodic dipping with galvanized boxed sections and strategic use of zinc plated panels in vulnerable areas. Protective under seal for all under body cabin area, wheel housings and engine area. Polypropylene bumper and side mouldings.

CLIMATE CONTROL

Four speed electric fan with five different air distribution modes and cab recirculation. Windshield side window defroster and defogger through side and front fixed position air vents. Temperature-controlled air conditioned cab.

OPTIONS

- AGile - 6 speed automated transmission.
- ECAS - Electronically Controlled Air Suspension on rear axle available.
- Passenger airbags with seat belt tensioners plus side window airbags.
- ESP - Electronic Stability Programme (includes ASR - Traction control, MSR - Motor Torque Reduction, HBA - Hydraulic Brake Assist, HILL HOLDER).
- Suspended and heated driver and passenger seats.

DIMENSIONS (mm)

	X	3750	4350
X Wheelbase		3750	4350
K Overall length		6515	7340
H Overall height (unladen)		2360	2345
C1 Front track		1725	1725
Rear track		1661	1661
Unladen frame height at front axle		638	636
T Unladen frame height at rear axle		785	786
Front ground clearance		171	171
Rear ground clearance		165	165
Y Rear overhang		1655	1890
Turning circle: kerb to kerb		13180	15020
Turning circle: wall to wall		14280	16120

BODY DIMENSIONS (mm)

	W	3737#	4562#
Maximum body length#		3737#	4562#
Maximum body width		2350	2350

MASS (kg)

GVM	6300	6300
Towing capacity with braked trailer*	3500*	3500*
Front axle capacity	2300	2300
Rear axle capacity	5000	5000
Kerb mass front axle	1575	1615
Kerb mass rear axle	900	895
Kerb mass total	2475	2510
Body and payload capacity	3825	3790

*Subject to individual state regulations and requirements.

#Determined by legislative constraints and/or technical criteria for optional ride & handling. Kerb masses are with full fuel tank, oil, water, spare wheel, tools and include driver at 75 Kg. Maximum body width subject to mirror and lighting requirements.

IVECO Trucks Australia Limited

A.B.N. 86 004 065 061

Princes Hwy, Dandenong, Victoria 3175

P.O. Box 117 Dandenong, Victoria 3175

Telephone: (03) 9238 2200

Facsimile: (03) 9238 2387

www.iveco.com.au

Daily Spec Sheet (MAY 2009)

DAILY

65C18D DUAL CAB CHASSIS SPECIFICATIONS

IVECO