

ENGINE

Cummins ISC-05 (ADR80/02 approved)
Type: Turbocharged, constant pressure direct injected diesel engine with cruise control and programmable hand throttle/ PTO control.
Number of cylinders: 6
RAC HP rating: 48.4
Total displacement: 8.3 litre
Maximum output: 260hp (194kW) @ 2000rpm
Maximum torque: 800 lb ft (1085Nm) @ 1300rpm
Maximum output: 285hp (213kW) @ 2000rpm
Maximum torque: 800 lb ft (1085Nm) @ 1300rpm
Maximum output: 315hp (235kW) @ 2000rpm
Maximum torque: 950 lb ft (1288Nm) @ 1300rpm
Governed engine speed: 2200rpm.
Clutch engagement torque: 678Nm.
Road speed limiting to 100kmh.
Idle timer. Perforated muffler heat shield.
Donaldson Cyclopac 356mm dry element air cleaner.
Optional: Exhaust brake.

TRANSMISSIONS

Allison Gen 4 3000 5 speed automatic in 4x2.
Allison Gen 4 3500 5 speed automatic in 6x4.
Allison Gen 4 3200 6 speed automatic with 315hp.
Eaton RTLO-12913 13 speed constant mesh.
Rear engine PTO with pump mounting bracket (manual only).
Transmission-mounted Chelsea PTO, 1.16 times engine speed with pump mounting brackets (automatic only).

REAR AXLE

Meritor RS23-161 (for 4x2)
Capacity: 10.4 tonne.
Ratios: 5.38
Optional: Driver-controlled differential locks.
Meritor MT20-145G (for 6x4 or 8x4) (Same as RT40-145G)
Capacity: 18.1 tonne.
Ratios: 5.29, 6.43.
Optional: Driver controlled differential locks both axles.

REAR SUSPENSION

International 3 Rod Vari-rate (for 4x2)
Type: Mechanical Spring with variable rate.
Capacity: 11.0 tonne.
Hendrickson PRIMAAX PAX230 (for 4x2)
Type: Air with shock absorbers and dump control.
Capacity: 10.0 tonne.
Hendrickson PRIMAAX PAX460 (for 6x4 or 8x4)
Type: Air with shock absorbers and dump control.
Capacity: 18.0 tonne.
Hendrickson HN402 (for 6x4 or 8x4)
Type: Walking Equalizing beam with rubber bolster VariRate springs and shock absorbers. Capacity: 18.0 tonne.

FRONT AXLE

Dana I-140SG
Type: Forged steel I beam.
Capacity: 6.6 tonne.

FRONT SUSPENSION

Single steer type: HD Multi-leaf springs with threaded pins and bushes and double acting shock absorbers.
Capacity: 7.2 tonne.
Twin Steer type: HD Multi-leaf springs with threaded pins and bushes and double acting shock absorbers.
Capacity: 13.4 tonne.
Optional: Airtek: Air suspension with integrated axle, leaf springs and shock absorbers.
Capacity: 6.6 tonne (single steer) 13.2 tonne (twin steer)

BRAKES

Type: Dual air S cam.
Front: Meritor Q-Plus 419mm diameter x 152mm drum brakes.
Rear: Meritor Q-Plus 419mm diameter x 178mm drum brakes.
Park: Front park brake on 4x2.
Automatic slack adjusters. Dessicant type air dryer (CR2000).
Air exhaust mufflers.

STEERING

Sheppard M110 power steering with gear-driven pump.
Tilting and telescoping steering column with 463mm diameter steering wheel (right-hand drive models only).

FUEL SYSTEM

270-litre cylindrical aluminium tanks mounted right hand side of chassis. Engine mounted paper element fuel filter.

CHASSIS

Type: High tensile, heat treated, alloy steel channel.
Yield strength: 760 MPa.
Standard chassis dimensions: 257mm x 89mm x 8mm.
Standard section modulus: 243cm³ per side.
Heavy-duty centrally-mounted front towing pin.
Square end of frame. Steel bumper bar.
Nudge bar fitted to left hand side (dual control only).
FUPD for all 4x2 and 6x4 models.
Optional:
Wrap reinforcement (8x4 models only) for tipping bodies
Mounting bracket for hydraulic pump (automatic models only).
Optional:
Mounting bracket for hydraulic pump (manual models only)
Inverted L reinforcement for applications requiring additional frame reinforcement (4x2 and 6x4).

ELECTRICAL SYSTEM

Type: 12 volt, negative to earth.
Batteries: 3 x 12V, 550amp SAE cold cranking current, maintenance free.
Alternator: 12V 130amp.
Headlamps: 60/55 watt circular quartz halogen.
Driving lights: 55 watt circular quartz halogen.
Reverse warning buzzer.
Isolation switch (Iveco Two Pole) mounted on battery box
Front left hand indicator guard.
Optional: Cab roof mounted revolving amber light.

CLUTCH

Eaton SAS 1402 twin plate ceramic with manual transmission.
Diameter: 356mm.
Lining area: 1208cm².

WHEELS & TYRES

Wheels: 335PCD steel 10-stud disc wheels.
Front tyres: Michelin XZE2+ 295/80R22.5 (6.5 tonne FA rating) 11R22.5 for 8x4. Tubeless radial
Rear tyres: Michelin XDE2+ 11R22.5 tubeless radial.
Spare rim supplied loose.
Optional:
6-spoke cast hubs with 8.25 x 22.5 DC.
Spare wheel carrier (supplied loose).
Alternative Michelin tyre sizes and tread patterns available.

COOLING SYSTEM

Radiator area: 5049cm².
Charge cooler frontal area: 4461cm² up to 285Hp & 5015 cm² for 315Hp.
Air to oil transmission cooler for automatic models mounted on the chassis.
Viscous drive fan, crankshaft driven.
Optional:
Supplementary cooling fan.
Heavy duty radiator guard and stone shield.

DRIVESHAFTS

Spicer 1810 Series main shaft with Eaton transmission.
Spicer 1710 Series main shaft with Allison transmission.
Spicer 1710 Series inter-axle shaft with all transmissions.

CAB CONSTRUCTION

2180mm wide galvanized steel cab with hydraulic lift and latch.
Four-point cab mounting system with rubber block front and air springs dampers at the rear. Double-sided zinc steel exterior and floor panels. Electro-phoretic deposited undercoat with acrylic hi-bake enamel finishing coat. Laminated safety glass windscreen, toughened safety glass elsewhere.

ACCO

**Compactor 4x2 6x4 8x4
SPECIFICATIONS**

IVECO

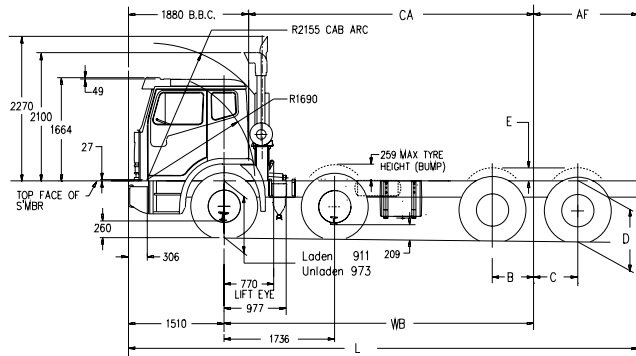
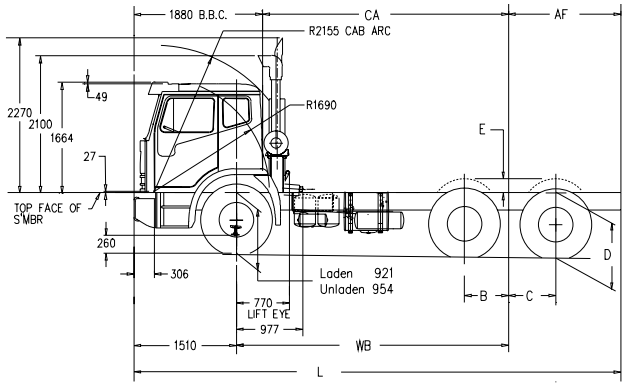

FEATURES

Isringhausen air-suspended driver's seat with integral lap/sash seat belt, fore aft isolator and adjustable lumbar support. Isringhausen fixed passenger's seat with integral lap/sash seat belt. Air suspended seats standard on dual control.

Power Windows. Air conditioning with pollen filter. Triple electric 2-speed windscreen wipers/washers with intermittent speed. Heater-demister with 3-speed fan including face level vents. Twin speaker, AM/FM radio/CD with auto tune, digital clock and removable face security. Heated west coast type heated mirrors with convex section. Jack, rim wrench, handle and extension. Interior and exterior sunvisors. Chassis-mounted dual air horns. In-cab body builder electrical and air. PTO throttle wiring connectors and 12V accessory socket. Heavy duty trim package comprising heavy duty Urethane floor mats, passenger foot rest, door scuff plates.

Remotely operated motorised mirrors. Fixed double (bench) passenger seat (single control only). Overhead console. Chassis prepared for key suppliers.

CAB Optional: Dual control pack

Standard ACCO cab with dual controls and air suspended driver and passenger seats. Comprising dual instrument panel, transmission temperature gauge, water temperature gauge, heated and motorised mirrors, unique wiper pattern on left-hand side of vehicle.

INSTRUMENTATION

Gauges: Electronic speedometer and tachometer, dual needle air pressure, coolant temperature, engine oil pressure, automatic transmission temperature (RHS only), voltmeter, hour meter and fuel level.

Warning lights: Brake failure, park brake activated, low engine oil pressure, turn signal on, hazard lights activated, high beam activated, cab latch insecure, power divider lock activated, driver controlled diff locks activated (where fitted), PTO activated, cruise control activated, engine ECU failure and low coolant level.

Warning buzzer: Low brake air pressure, low oil pressure, low auto transmission coolant level horn alert sounds if driver door opens and park brake has not been applied.

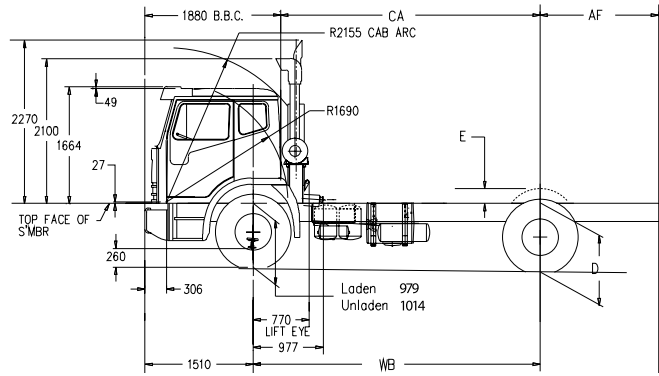

MASS RATINGS

GVM 4x2	16.5 tonne
GCM 4x2	30.0 tonne
GVM 6x4	24.5 tonne
GCM 6x4	30.0 tonne
GVM 8x4	30.0 tonne
GCM 8x4	30.0 tonne

All ratings apply with suitably rated engine, transmission, suspension and tyres. GVM, GCM, driveline, frame, and suspension combinations are subject to application engineering review.

CHASSIS DIMENSIONS (Dimensions in mm)

4x2	5000	5500
WB	4400	5000
AF	1235	1270
CA	4030	4630
L	7630	8450
Turning circle*	14690	16980

6x4	5200	5800
WB	4800	5000
AF	1645	1740
CA	4430	4630
L	8180	8250
Turning circle*	19740	20560

8x4	21390
WB	5840
AF	2100
CA	5470
L	9450
Turning circle*	21430

Chassis Width: Standard 867 With reinforcement 883

*For unladen cab-chassis. For wall-to-wall turning circle add 1740 mm. Refer to Bodybuilder diagrams for fuel tank lengths, locations and further details.

SUSPENSION (Dimensions in mm)

	B	C	D	E
	Laden		Unladen	
International 3 4x2	-	-	944	1037
Rod VariRate				105
Hendrickson PAX230 4x2	-	-	987	987
Hendrickson PAX460				105
6x4 & 8x4	664	669	987	987
Hendrickson HN402				114
6x4 & 8x4	650	694	964	1041
				172

IVECO Trucks Australia Limited

A.B.N. 86 004 065 061

Princes Hwy, Dandenong, Victoria 3175

P.O. Box 117 Dandenong, Victoria 3175

Telephone: (03) 9238 2200

Facsimile: (03) 9238 2387

www.iveco.com.au

ACCO Spec Sheet (MAY 2009)

ACCO

Compactor 4x2 6x4 8x4 SPECIFICATIONS

IVECO