

**SPECIFICATION SHEET**

# DAILY

**65C18**

**DUAL CAB CHASSIS**

L I G H T  
R A N G E



**IVECO**

# 65C18

DUAL CAB CHASSIS

## ENGINE

IVECO FIC 3.0l - 4 stroke diesel with direct-injection, turbocharger and intercooler. Water-cooled with electromagnetic fan. Cast-iron engine block with aluminium cylinder head. New generation common rail injection system. Exhaust gas recirculation system - EGR. Exhaust system with diesel particulate filter (CRT - Continuously Regenerating Trap) and muffler longitudinally positioned on the right side and stub-pipe located mid-way down right side of vehicle.

### Basic data

Number of cylinders: 4 (16 valves) vertical in line.  
Bore x stroke: 95.8 mm x 104 mm.  
Total displacement: 2998 cm<sup>3</sup>

Engine	3.0 HPT*
Power (hp/Kw)	176/130
At rpm:	3200-3500
Torque (Nm/lbft)	400/295
At rpm:	1250-3000

\*HPT: High Performance Turbine with VGT – Variable Geometry Turbo.

## FRAME

C Section steel longitudinal side members with tapered ends and tubular cross members.

Wheelbase (mm)	3750	4350
Cross members	6	7
Side member height (mm)	184	184
Side member width (mm)	69	69
Side member thickness (mm)	5	5

## TRANSMISSION

Six speed synchromesh overdrive manual transmission.  
Type: 6S400 OD.

### Gear ratios

1st	2nd	3rd	4th	5th	6th	Rev.1st
5.373	3.154	2.041	1.365	1.000	0.791	4.838

Optional transmission automated: *AGile*

Six speed synchromesh overdrive automated transmission.  
Type: 6AS400

### Gear ratios

1st	2nd	3rd	4th	5th	6th	Rev.1st
5.373	3.154	2.041	1.365	1.000	0.791	4.838

## CLUTCH

Single dry plate.

Hydraulically controlled.

External diameter: 280 mm (11").

## AXLES

Front: Iveco 5823 independent, 2300 kg capacity.

Rear: Iveco 450517 full-floating single reduction, 5000 kg capacity.

Rear axle ratio: 4.30:1

## SUSPENSION

Front: Independent with adjustable torsion bar anchored to the chassis integrated with double-acting telescopic shock absorbers and anti-roll bar.

Rear: Multileaf spring, rubber rebound bump stops, heavy duty shock absorbers and anti-roll bar.

## LIGHTING & SIGNALING SYSTEM

Halogen headlamps; twin front and rear fog lamps and twin reverse lamps.

## WHEELS / TYRES

Tyres: 225/75 R16.

Wheels: 6JK 16H2.

3.0 HPT - 176 HP E4

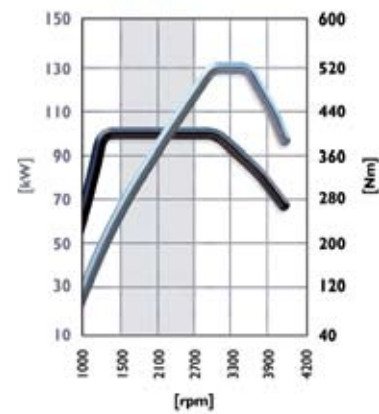

## ELECTRICAL SYSTEM

Battery: 12V - 110 Ah.

Alternator: 12V - 140 A.

Trailer wiring to rear of chassis.

## BRAKING SYSTEM

ABS 8 with EBD - Electronic Brake force Distribution.

Front / Diameter: Ventilated disc brakes / 301 mm.

Rear / Diameter: Disc brakes / 306 mm.

Parking brake: Manual brake operating on rear axle.

Service brakes:

Dual circuit with vacuum servo.

Pad wear warning light for front and rear brakes.

## STEERING

Power steering. Steering wheel diameter 420 mm.

Three piece steering column with connecting universal joints.

## OTHER EQUIPMENT

- Spare wheel carrier located under the rear overhang.
- 100 litres on nearside with locking fuel cap.
- Front tow hook.

## CABIN

- Drivers airbag with seat belt pretensioners.
- Fully adjustable driver's seat with headrest.
- Three point inertia reel belt on all seats except on the rear middle seat.
- Dual passenger seats with headrests.
- Cruise control.
- Electric windows.
- Exterior mirror with integrated wide angle and direction indicators, heated and electrically adjustable.
- Overhead console with storage shelf and standard space for additional equipment.
- Large dual storage pockets in doors.
- Underseat storage.
- Document storage compartment.
- Insulated compartment located on the dashboard.
- Body builders connectors.
- Single piece floor mat.
- 2 cup holders plus 1 bottle holder.
- Glove compartment with added storage.
- Additional in-dash storage.
- Clip holder.

# 65C18

## DUAL CAB CHASSIS

### DASHBOARD

- New soft-feeling anti-reflective material.
- Analogue electronic speedometer.
- Electronic tachometer.
- Fuel level indicator with reserve light indicator.
- Coolant temperature indicator with high temperature indicator light.
- Instrument light dimmer switch.
- Dash-mounted gear lever.
- 3 DIN drawers, one of which carries CD Player.
- LCD Display Panel includes: odometer; trip computer with distance, time, fuel consumption etc; headlamp orientation (dip/main); clock, external temperature, service indicator; gear selected with the automated transmission (only on *AGile*).
- Stereo radio/CD player (with CAN security).

### SECURITY

- Central locking with remote control and door locking management
- Steering lock.
- Engine immobilizer actuated by transponder on ignition key.

### CONSTRUCTION & FINISH

C-section steel longitudinal side members and tubular cross members with pressed steel unitary construction body mounted on rubber bushes. Anti-corrosion protection includes full catheporetic dipping with galvanized boxed sections and strategic use of zinc plated panels in vulnerable areas. Protective under seal for all under body cabin area, wheel housings and engine area. Polypropylene bumper and side mouldings.

### CLIMATE CONTROL

Four speed electric fan with five different air distribution modes and cab recirculation. Windshield side window defroster and defogger through side and front fixed position air vents. Temperature-controlled air conditioned cab.

### OPTIONS

- *AGile* - 6 speed automated transmission.
- ECAS - Electronically Controlled Air Suspension on rear axle available only with *AGile*.
- Passenger airbags with seat belt tensioners plus side window airbags.
- ESP - Electronic Stability Programme (includes ASR - Traction control, MSR - Motor Torque Reduction, HBA - Hydraulic Brake Assist, HILL HOLDER).
- Suspended and heated driver and passenger seats.

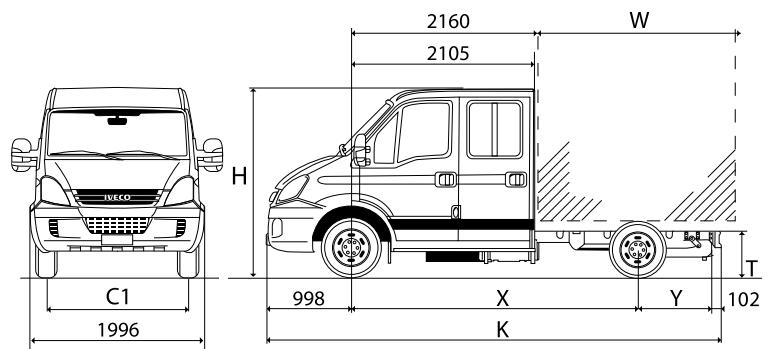

### DIMENSIONS (mm)

X	Wheelbase	3750	4350
K	Overall length	6515	7340
H	Overall height (unladen)	2360	2345
C1	Front track	1725	1725
	Rear track	1661	1661
	Unladen frame height at front axle	638	636
T	Unladen frame height at rear axle	785	786
	Front ground clearance	171	171
	Rear ground clearance	165	165
Y	Rear overhang	1655	1890
	Turning circle: kerb to kerb	13180	15020
	Turning circle: wall to wall	14280	16120

#### Body Dimensions

W	Maximum body length <sup>#</sup>	3737 <sup>#</sup>	4562 <sup>#</sup>
	Maximum body width	2350	2350

#### Mass (kg)

	GVM	6300	6300
	Towing capacity with braked trailer*	3500*	3500*
	Front axle capacity	2300	2300
	Rear axle capacity	5000	5000
	Kerb mass front axle	1575	1615
	Kerb mass rear axle	900	895
	Kerb mass total	2475	2510
	Body and payload capacity	3825	3790

\* Subject to individual state regulations and requirements.

<sup>#</sup> Determined by legislative constraints and/or technical criteria for optional ride and handling.

Kerb masses are with full fuel tank, oil, water, spare wheel, tools and include driver at 75 Kg. Maximum body width subject to mirror and lighting requirements.



## 65C18

### Important

The illustrations and specifications ("material") in this brochure were correct at the time of publication but are subject to change without notice. The material is provided by way of general description only and all measurements and specifications should be regarded as approximate. Availability of vehicles and all other items referred to in this brochure will depend on local and overseas supply conditions from time to time. Accordingly, before placing an order you should consult your nearest authorised Iveco dealer to obtain accurate and up-to-date information on models specifications, features, availability and prices.

## **IVECO**

### **Iveco Trucks Australia Limited**

A.B.N 86 004 065 061

Princes Hwy, Dandenong Victoria 3175

P.O. Box 117 Dandenong Victoria 3175

Telephone: (03) 9238 2200

Facsimile: (03) 9238 2387

[www.iveco.com.au](http://www.iveco.com.au)

The information in this literature is intended to be of general nature only. Iveco reserves the right to modify or change specifications at any time. For more detailed information refer to your dealer.